

# WTR SERIES

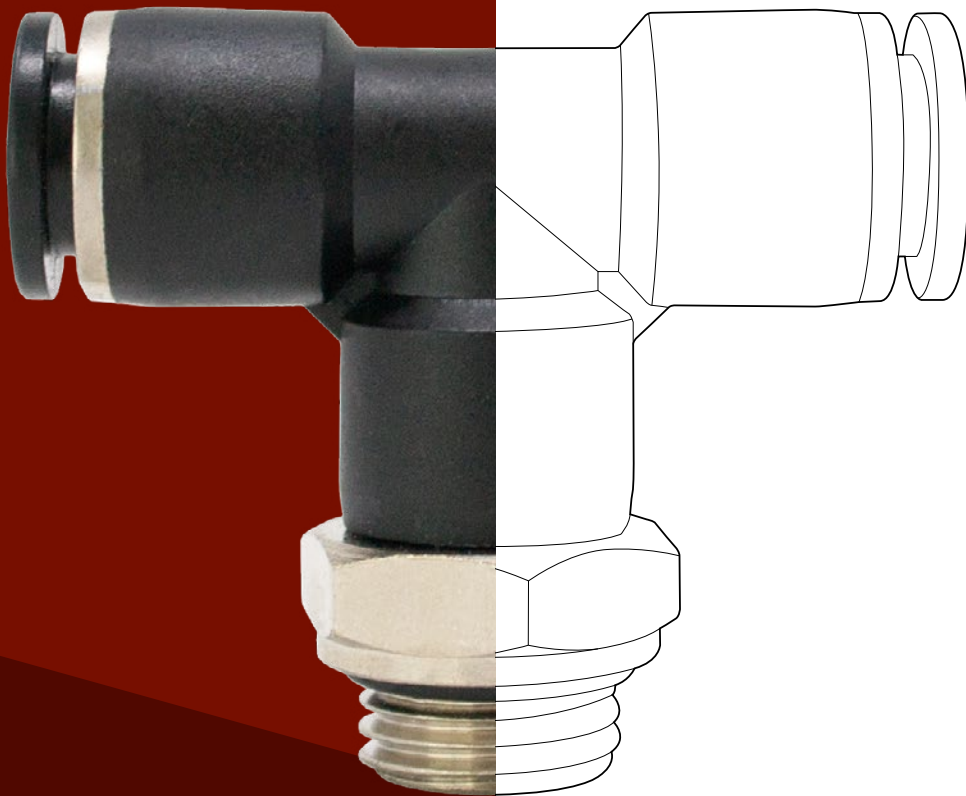

## WTR SERIES / PUSH-IN FITTINGS

p. 10 / **WTRC-R**p. 11 / **WTRC-G**p. 12 / **WTRC-R**p. 12 / **WTRC-G**p. 13 / **WTRCF-G**p. 13 / **WTRMF-G**p. 14 / **WTRMM**p. 14 / **WTRSL-R**p. 15 / **WTRSL-G**p. 15 / **WTRL-R**p. 16 / **WTRL-G**p. 17 / **WTRLL-R**p. 17 / **WTRLL-G**p. 18 / **WTRLH-R**p. 18 / **WTRLH-G**p. 19 / **WTRLF-G**p. 19 / **WTRLM**p. 20 / **WTRH-R**p. 20 / **WTRH-G**p. 21 / **WTRHF-R**p. 21 / **WTRHF-G**p. 22 / **WTRT-R**p. 22 / **WTRT-G**p. 23 / **WTRST-R**p. 23 / **WTRST-G**p. 24 / **WTRWT-R**p. 24 / **WTRWT-G**p. 25 / **WTRKD-R**p. 25 / **WTRKD-G**p. 26 / **WTRUC**p. 26 / **WTRG**p. 26 / **WTRUL**p. 27 / **WTRUT**p. 27 / **WTRGT**p. 27 / **WTRY**p. 27 / **WTRW**p. 28 / **WTRZA**p. 28 / **WTRK**p. 28 / **WTRKJ**p. 28 / **WTRGJ**p. 29 / **WTRLJ**p. 29 / **WTRLGJ**p. 29 / **WTRTJ**p. 29 / **WTRTGJ**p. 30 / **WTRYJ**p. 30 / **WTRWJ**p. 30 / **WTRKJ**p. 30 / **WTRPF**p. 31 / **WTRIJ**p. 31 / **WTRIG**p. 31 / **WTRP**p. 31 / **WTRUC-PRD**p. 32 / **WTRCV**

## WTR SERIES / BANJO FLOW REGULATORS

p. 37 / **WTRFR-R**p. 37 / **WTRFR-R-IN**p. 38 / **WTRFR-G**p. 38 / **WTRFR-G-IN**

## WTR SERIES / FLAT FLOW REGULATORS

p. 41 / **WTRNSF**

## WTR SERIES / HAND VALVES

p. 45 / **WTRFS-R**p. 45 / **WTRFS-G**p. 46 / **WTRSF-R**p. 46 / **WTRSF-G**p. 47 / **WTRSS-R**p. 47 / **WTRSS-G**p. 48 / **WTRFF**

# WTR SERIES PUSH-IN FITTINGS

## PLUS

**COMPLETE RANGE** thanks to 20 years of experience in the industry

**HIGHEST LEVEL OF PERFORMANCES**  
working pressure up to 16 bar,  
increased working temperature from  
-20°C to 80°C (push-in fittings)

**PLASTIC STEM SYSTEM** to allow  
connection with different kind of fittings

**MADE FROM TOP QUALITY  
TECNOPOLYMERS** to guarantee long-  
lasting components

**100% LEAK-PROOF TESTED**

**IN COMPLIANCE WITH ISO 14743  
(EXCEPT Ø16)**

**SUITABLE FOR VACUUM  
APPLICATIONS**

**STATIC GRIPPING SYSTEM** in order  
to stop all movement of the tube  
when inserted, granting a leak-proof  
connection

Every fitting is **DESIGNED TO  
GUARANTEE MAXIMUM POSSIBLE  
FLOW RATE** accordingly to the  
diameter of the tube and the thread



p. 10 / **WTRC-R**



p. 11 / **WTRC-G**



p. 12 / **WTRC-R**



p. 12 / **WTRC-G**



p. 13 / **WTRCF-G**



p. 13 / **WTRMF-G**



p. 14 / **WTRMM**



p. 14 / **WTRSL-R**



p. 15 / **WTRSL-G**



p. 15 / **WTRL-R**



p. 16 / **WTRL-G**



p. 17 / **WTRLL-R**



p. 17 / **WTRLL-G**



p. 18 / **WTRLH-R**



p. 18 / **WTRLH-G**



p. 19 / **WTRLF-G**



p. 19 / **WTRLM**



p. 20 / **WTRH-R**



p. 20 / **WTRH-G**



p. 21 / **WTRHF-R**



p. 21 / **WTRHF-G**



p. 22 / **WTRT-R**



p. 22 / **WTRT-G**



p. 23 / **WTRST-R**



p. 23 / **WTRST-G**



p. 24 / **WTRWT-R**



p. 24 / **WTRWT-G**



p. 25 / **WTRKD-R**



p. 25 / **WTRKD-G**



p. 26 / **WTRUC**



p. 26 / **WTRG**



p. 26 / **WTRUL**



p. 27 / **WTRUT**



p. 27 / **WTRGT**



p. 27 / **WTRY**



p. 27 / **WTRW**



p. 28 / **WTRZA**



p. 28 / **WTRK**



p. 28 / **WTRKG**



p. 28 / **WTRGJ**



p. 29 / **WTRLJ**



p. 29 / **WTRLGJ**



p. 29 / **WTRTJ**



p. 29 / **WTRTGJ**



p. 30 / **WTRYJ**



p. 30 / **WTRWJ**



p. 30 / **WTRKJ**



p. 30 / **WTRPF**



p. 31 / **WTRIJ**



p. 31 / **WTRIG**



p. 31 / **WTRP**



p. 31 / **WTRUC-PRD**



p. 32 / **WTRCV**

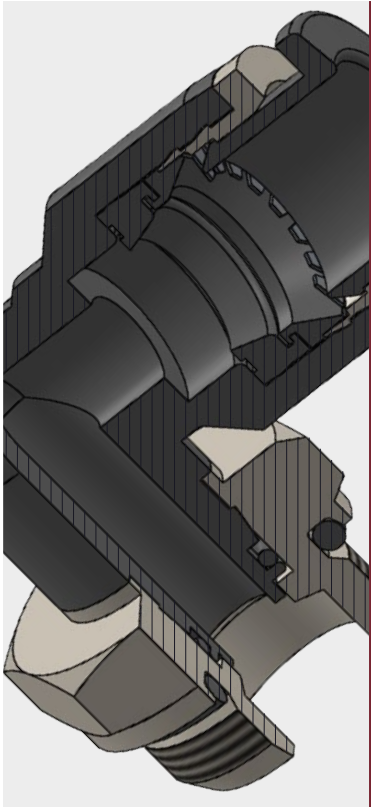

-20°C ÷ 80°C



**Working pressure:**

16 Bar

**Negative pressure:**

- 0,95 Bar (- 95 kPa)



Compressed air & Vacuum  
(do not use in water application)



- Taper gas BSPT ISO 7  
from R1/8" to R1/2" with teflon

- Parallel gas BSPP ISO 228  
from G1/8" to G1/2"

- Metric ISO 262  
M5, M6 and M7



Polyamide PA,  
Polyurethane PU,  
Polyethylene PE

**AVAILABILITY**

Available with NPT thread on request



Body: Nickel-plated brass and PBT

Collet: POM

Collar: Zinc

Lock claw: Stainless steel AISI 301

Back ring: POM

Seal: NBR

O-ring: NBR

**SILICONE FREE**



Products in compliance with  
EC Regulation 1907/2006

**RoHS3**

Products in compliance with  
the directive EU 2015/863

**CONSTRUCTION DETAILS**

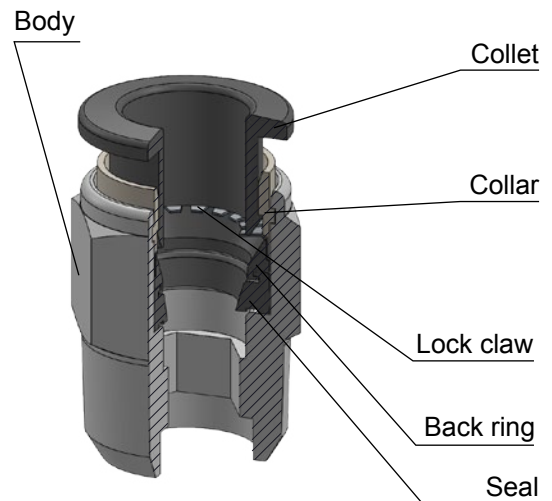
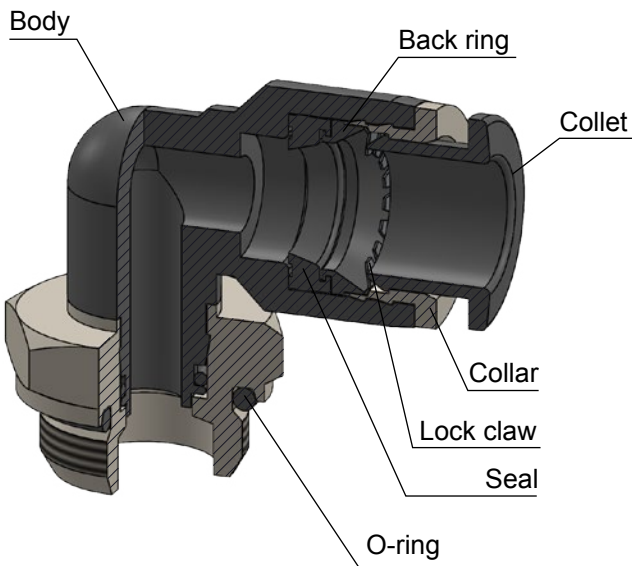

**TIGHTENING TORQUE**

TAPER GAS BSPT ISO 7

THREAD	1/8"	1/4"	3/8"	1/2"
Nm	7	12	22	28

**TIGHTENING TORQUE**

PARALLEL GAS BSPP ISO 228 & METRIC ISO 262

THREAD	M5x0,8	M6x1	M7x1	1/8"	1/4"	3/8"	1/2"
Nm	1,5	2	3	6	10	18	23

**INSERTION OF THE TUBE INTO THE FITTING**

- Make sure the tube is fully inserted into the fitting.
- To insert the tube into the fitting cut the tube off square (90°), insert tube up to the fitting end stop, and pull back gently to make sure it is correctly connected.
- If there is any damage or scratches on the tube surface the tube is an oval shape, air leakage and tube release may occur. Check the tube condition carefully.
- The OD of polyurethane tube expands when pressure is applied. Reinsertion into the fitting may not always be possible. Check the OD of the tube and renew it the expansion is out of tolerance.

**DISCONNECTION OF THE TUBE FROM THE FITTING**

- Make sure the pressure in the system is zero before releasing the tube from the fitting.
- To release the tube, press the release sleeve towards the fitting with one hand (1) and pull the tube away from the fitting with the other hand (2).
- Always remove the section of tube previously inserted into the fitting before reinserting the tube by cutting back the tube. Always use the correct tube cutter in order to cut the tube square and free of damage.

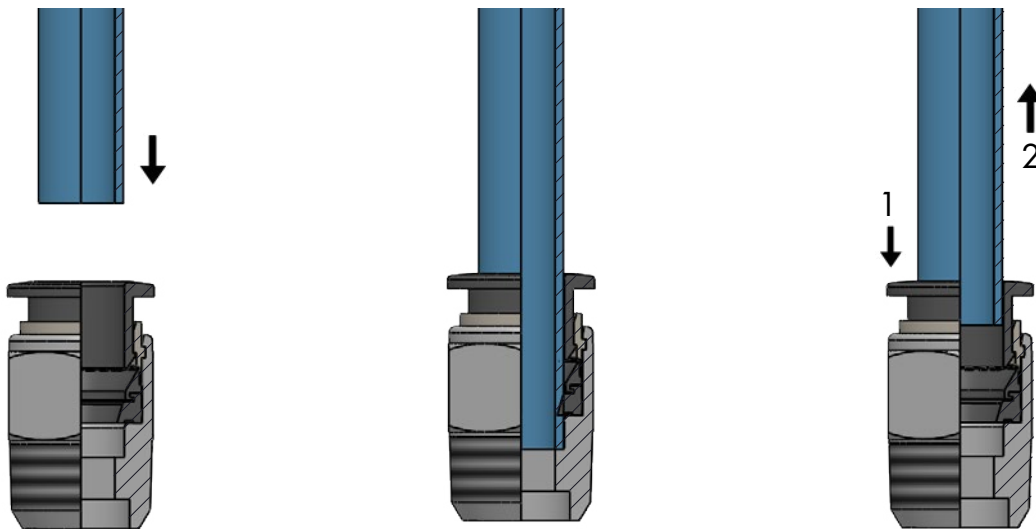

**TOLERANCE - METRIC TUBE**

Ø TUBE (mm)	4	6	8	10	12	14	16
TOLERANCE (mm)	± 0,1	± 0,1	± 0,1	± 0,1	± 0,15	± 0,15	± 0,15

**INSERTION DEPTH - METRIC TUBE**

Ø TUBE (mm)	4	6	8	10	12	14	16
TUBE INSERTION LENGTH (mm)	15	16,5	18,8	20,1	22,9	22,9	23,6

**WTRC-R**

Male connector BSPT thread nickel-plated

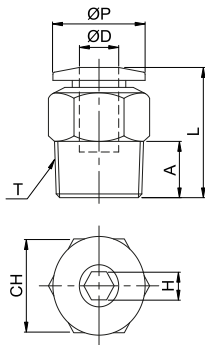

CODE	ØD	T	ØP	A	L	CH	H	g
WTRC04R01	4	R 1/8"	9,8	7	19,3	10	3	6,2
WTRC04R02		R 1/4"	9,8	9,5	17,9	14	3	9,8
WTRC06R01	6	R 1/8"	11,9	7	20,4	12	4	6,9
WTRC06R02		R 1/4"	11,9	9,5	22,7	14	4	13,3
WTRC06R03		R 3/8"	11,9	10,5	20,7	17	4	19,9
WTRC06R04		R 1/2"	11,9	13,5	24,7	21	4	39,8
WTRC08R01	8	R 1/8"	13,8	7	25,4	14	5	10
WTRC08R02		R 1/4"	13,8	9,5	24,9	14	6	11,9
WTRC08R03		R 3/8"	13,8	10,5	21,9	17	6	17,5
WTRC08R04		R 1/2"	13,8	13,5	25,9	21	6	37,6
WTRC10R01	10	R 1/8"	17,2	7	27,7	17	5	16,4
WTRC10R02		R 1/4"	17,2	9,5	29,5	17	6	18,6
WTRC10R03		R 3/8"	17,2	10,5	27	17	8	20,7
WTRC10R04		R 1/2"	17,2	13,5	25,3	21	8	34,6
WTRC12R02	12	R 1/4"	19,6	9,5	32,9	20	6	24,5
WTRC12R03		R 3/8"	19,6	10,5	29,9	20	8	25,3
WTRC12R04		R 1/2"	19,6	13,5	32,9	21	8	41
WTRC16R03	16	R 3/8"	24,3	10,5	37,6	24	8	42
WTRC16R04		R 1/2"	24,3	13,5	35,6	24	10	42,1



**WTRC-G**

Male connector BSPP & metric thread nickel-plated

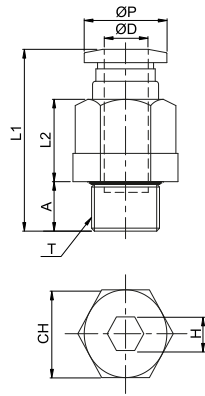

CODE	ØD	T	ØP	A	L1	L2	CH	H	g
WTRC04M5	4	M5x0,8	9,8	3,8	20,1	-	10	2	5,7
WTRC04M6		M6x1	9,8	4,5	20,8	-	10	2,5	6,1
WTRC04M7		M7x1	9,8	4,5	20,8	-	10	2,5	6,9
WTRC04G01		G 1/8"	9,8	5	19,3	7,4	10	3	7,4
WTRC04G02		G 1/4"	9,8	5,8	16,6	3,9	10	3	9,4
WTRC06M5	6	M5x0,8	11,9	3,8	21,2	-	12	2	7,4
WTRC06M6		M6x1	11,9	4,5	21,7	-	12	2,5	7
WTRC06M7		M7x1	11,9	4,5	21,7	-	12	2,5	7,2
WTRC06G01		G 1/8"	11,9	5	19,9	6,7	12	4	7,5
WTRC06G02		G 1/4"	11,9	5,8	20,4	6,4	12	4	10,8
WTRC06G03	G 3/8"	11,9	6,8	20	4,5	12	4	17	
WTRC06G04	G 1/2"	11,9	8	21,7	4,5	12	4	27,5	
WTRC08G01	8	G 1/8"	13,8	5	24,4	11,1	14	5	11,7
WTRC08G02		G 1/4"	13,8	5,8	22,2	7	14	6	11,1
WTRC08G03		G 3/8"	13,8	6,8	21,2	4,5	14	6	15,7
WTRC08G04		G 1/2"	13,8	8	22,9	4,5	14	6	27
WTRC10G01	10	G 1/8"	17,2	5	26,3	11	17	5	15,9
WTRC10G02		G 1/4"	17,2	5,8	27,5	13,9	17	6	20,4
WTRC10G03		G 3/8"	17,2	6,8	25	8,9	17	8	20,6
WTRC10G04		G 1/2"	17,2	8	22,7	4,9	17	8	28,5
WTRC12G02	12	G 1/4"	19,6	5,8	31,2	12	20	6	26,3
WTRC12G03		G 3/8"	19,6	6,8	28,2	11	20	8	24,3
WTRC12G04		G 1/2"	19,6	8	28,9	9,5	20	8	33,3
WTRC14G03	14	G 3/8"	21,8	6,8	31,8	13	21	8	30
WTRC14G04		G 1/2"	21,8	8	29,5	10	24	10	20
WTRC16G03	16	G 3/8"	24,3	6,8	34,9	14,5	24	8	42
WTRC16G04		G 1/2"	24,3	8	36,1	18	24	10	50,7

**WTROC-R**

Male connector round body with internal hexagon BSPT thread nickel-plated

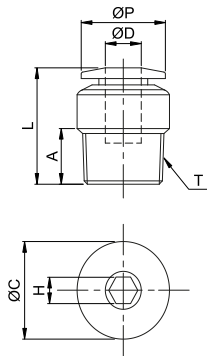

CODE	ØD	T	ØP	ØC	A	L	H	g
WTROC04R01	4	R 1/8"	9,8	10	7	19,3	3	5,6
WTROC04R02		R 1/4"	9,8	14	9,5	17,9	3	11,2
WTROC06R01	6	R 1/8"	11,9	12	7	20,4	4	6,3
WTROC06R02		R 1/4"	11,9	14	9,5	22,7	4	12,5
WTROC06R03		R 3/8"	11,9	17	10,5	20,7	4	19
WTROC08R01	8	R 1/8"	13,8	14	7	25,4	5	10,2
WTROC08R02		R 1/4"	13,8	14	9,5	24,9	6	13,1
WTROC08R03		R 3/8"	13,8	17	10,5	21,9	6	17,3
WTROC08R04		R 1/2"	13,8	21	13,5	25,9	6	37,9
WTROC10R01	10	R 1/8"	17,2	17	7	27,7	5	20,8
WTROC10R02		R 1/4"	17,2	17	9,5	29,5	6	22,5
WTROC10R03		R 3/8"	17,2	17	10,5	27	8	22,6
WTROC10R04		R 1/2"	17,2	21	13,5	25,3	8	34
WTROC12R02	12	R 1/4"	19,6	20	9,5	32,9	6	21,5
WTROC12R03		R 3/8"	19,6	20	10,5	29,9	8	22,2
WTROC12R04		R 1/2"	19,6	21	13,5	32,9	8	37,3

**WTROC-G**

Male connector round body with internal hexagon metric thread nickel-plated

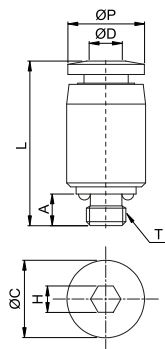

CODE	ØD	T	ØP	ØC	A	L	H	g
WTROC04M5	4	M5x0,8	9,8	10	3,8	20,1	2	5,2
WTROC04M6		M6x1	9,8	10	4,5	20,8	2	5,6
WTROC06M5	6	M5x0,8	11,9	12	3,8	21	2	6,8
WTROC06M6		M6x1	11,9	12	4,5	21,7	2	7,2

**WTRCF-G**

Female connector BSPP thread nickel-plated

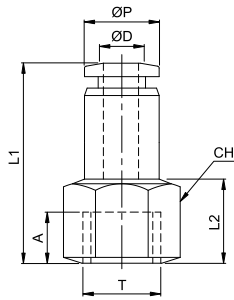

CODE	ØD	T	ØP	A	L1	L2	CH	g
WTRCF04G01	4	G 1/8"	9,8	7	23,3	9,5	14	12,5
WTRCF04G02		G 1/4"	9,8	9	25,3	11,5	17	18
WTRCF06G01	6	G 1/8"	11,9	7	24,4	10	14	15
WTRCF06G02		G 1/4"	11,9	9	26,4	12	17	19,3
WTRCF06G03		G 3/8"	11,9	10	27,4	13	19	26,3
WTRCF08G01	8	G 1/8"	13,8	7	25,9	10	14	15,8
WTRCF08G02		G 1/4"	13,8	9	27,9	12	17	19,4
WTRCF08G03		G 3/8"	13,8	10	28,9	13	19	18,4
WTRCF08G04		G 1/2"	13,8	12	30,9	15	24	32,8
WTRCF10G01	10	G 1/8"	17,2	7	27,7	10	17	28,5
WTRCF10G02		G 1/4"	17,2	9	29,7	13,3	17	27
WTRCF10G03		G 3/8"	17,2	10	30,7	14,3	19	24,6
WTRCF10G04		G 1/2"	17,2	12	32,7	16,3	24	38,5
WTRCF12G02	12	G 1/4"	19,6	9	32,9	11	20	44,2
WTRCF12G03		G 3/8"	19,6	10	33,9	12	20	35,9
WTRCF12G04		G 1/2"	19,6	12	35,9	15,5	24	34,2

**WTRMF-G**

Bulkhead female connector BSPP thread nickel-plated

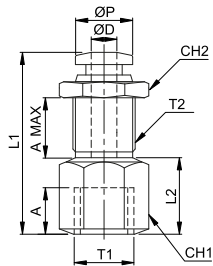

CODE	ØD	T1	T2	ØP	A	A MAX	L1	L2	CH1	CH2	g
WTRMF04G01	4	G 1/8"	M12x1	9,8	7	5,4	23,3	9,5	14	14	15,5
WTRMF04G02		G 1/4"	M12x1	9,8	9	5,4	25,4	11,6	17	14	20,4
WTRMF06G01	6	G 1/8"	M14x1	11,9	7	6,9	24,2	7	17	17	26,3
WTRMF06G02		G 1/4"	M14x1	11,9	9	6,9	29,2	12	17	17	26,5
WTRMF06G03		G 3/8"	M14x1	11,9	10	6,9	30,2	13	19	17	35,1
WTRMF08G01	8	G 1/8"	M16x1	13,8	7	9,4	26,4	5	19	19	32
WTRMF08G02		G 1/4"	M16x1	13,8	9	9,4	34,4	12	19	19	42,4
WTRMF08G03		G 3/8"	M16x1	13,8	10	9,4	34,4	13	19	19	42,4
WTRMF08G04		G 1/2"	M16x1	13,8	12	9,4	36,4	15	24	19	47,7
WTRMF10G01	10	G 1/8"	M20x1	17,2	7	9,4	29	7,7	21	24	52,8
WTRMF10G02		G 1/4"	M20x1	17,2	9	9,4	31	9,7	21	24	53,5
WTRMF10G03		G 3/8"	M20x1	17,2	10	9,4	34,3	13	21	24	53,8
WTRMF10G04		G 1/2"	M20x1	17,2	12	9,4	36,3	15	24	24	58,8
WTRMF12G02	12	G 1/4"	M22x1,5	19,6	9	10,9	33,5	9,1	24	27	68,2
WTRMF12G03		G 3/8"	M22x1,5	19,6	10	10,9	34,4	10	24	27	62,7
WTRMF12G04		G 1/2"	M22x1,5	19,6	12	10,9	39,4	15	24	27	62,3

**WTRMM**

## Bulkhead connector nickel-plated

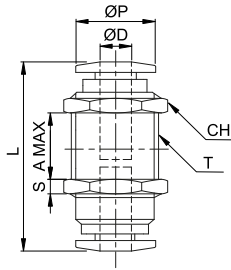

CODE	ØD	T	ØP	A MAX	L	S	CH	g
WTRMM0400	4	M12x1	9,8	8,2	30,1	3,5	14	15,4
WTRMM0600	6	M14x1	11,9	8,5	31,8	4	17	21,4
WTRMM0800	8	M16x1	13,8	8,8	35,3	4,5	19	26,8
WTRMM1000	10	M20x1	17,2	11,5	39	5	24	52,7
WTRMM1200	12	M22x1	19,6	12,8	45,3	5	27	59,8

**WTRSL-R**

## Short swivel male elbow BSPT thread nickel-plated

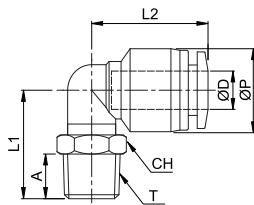

CODE	ØD	T	ØP	A	L1	L2	CH	g
WTRSL04R01	4	R 1/8"	11,1	7	16	17,5	10	5,8
WTRSL04R02		R 1/4"	11,1	9,5	19,5	17,5	14	6,3
WTRSL06R01	6	R 1/8"	13	7	17	19	10	6,4
WTRSL06R02		R 1/4"	13	9,5	20,5	19	14	12,4
WTRSL06R03		R 3/8"	13	10,5	22	19	17	14,2
WTRSL06R04		R 1/2"	13	13,5	25,5	19	21	17,3
WTRSL08R01	8	R 1/8"	15,1	7	21,3	22,8	12	11,5
WTRSL08R02		R 1/4"	15,1	9,5	21,5	22,8	14	13,3
WTRSL08R03		R 3/8"	15,1	10,5	23	22,8	17	20,3
WTRSL08R04		R 1/2"	15,1	13,5	26,5	22,8	21	21,9
WTRSL10R01	10	R 1/8"	18,8	7	25,5	26,3	14	15,4
WTRSL10R02		R 1/4"	18,8	9,5	26	26,3	14	18,4
WTRSL10R03		R 3/8"	18,8	10,5	25	26,3	17	21,9
WTRSL10R04		R 1/2"	18,8	13,5	28,5	26,3	21	24,8
WTRSL12R02	12	R 1/4"	21,5	9,5	29,5	29,6	17	33,6
WTRSL12R03		R 3/8"	21,5	10,5	26,5	29,6	17	36,2
WTRSL12R04		R 1/2"	21,5	13,5	30	29,6	21	39,5

**WTRSL-G**

Short swivel male elbow BSPP & metric thread nickel-plated

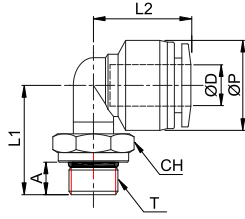

CODE	ØD	T	ØP	A	L1	L2	CH	g
WTRSL04M5	4	M5x0,8	11,1	3,8	15,3	17,5	8	5,2
WTRSL04M7		M7x1	11,1	4,5	17	17,5	10	6,1
WTRSL04G01		G 1/8"	11,1	4,8	14,8	17,5	14	7,6
WTRSL04G02		G 1/4"	11,1	5,5	16	17,5	17	11,3
WTRSL06M5	6	M5x0,8	13	3,8	15,3	19	8	5,8
WTRSL06M7		M7x1	13	4,5	17	19	10	6,7
WTRSL06G01		G 1/8"	13	4,8	15,8	19	14	8,3
WTRSL06G02		G 1/4"	13	5,5	17	19	17	13,3
WTRSL06G03	6	G 3/8"	13	6,5	18,5	19	20	16,8
WTRSL06G04		G 1/2"	13	7,5	19,5	19	24	20,1
WTRSL08G01		G 1/8"	15,1	4,8	20	22,8	14	11,9
WTRSL08G02		G 1/4"	15,1	5,5	18	22,8	17	13,8
WTRSL08G03	8	G 3/8"	15,1	6,5	19,5	22,8	20	21,2
WTRSL08G04		G 1/2"	15,1	7,5	20,5	22,8	24	23,9
WTRSL10G01		G 1/8"	18,8	4,8	24,3	26,3	14	21,3
WTRSL10G02		G 1/4"	18,8	5,5	23,1	26,3	17	24,3
WTRSL10G03	10	G 3/8"	18,8	6,5	21,5	26,3	20	27,6
WTRSL10G04		G 1/2"	18,8	7,5	22,5	26,3	24	31,2
WTRSL12G02		G 1/4"	21,5	5,5	26,5	29,6	17	33,8
WTRSL12G03		G 3/8"	21,5	6,5	23	29,6	20	35,6
WTRSL12G04	12	G 1/2"	21,5	7,5	24	29,6	24	39,8

**WTRL-R**

Swivel male elbow BSPT thread nickel-plated

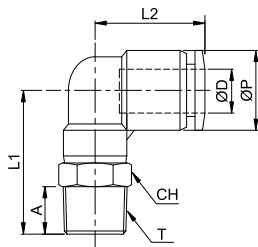

CODE	ØD	T	ØP	A	L1	L2	CH	g
WTRLO4R01	4	R 1/8"	11,1	7	23,5	17,5	10	8,1
WTRLO4R02		R 1/4"	11,1	9,5	27	17,5	14	13,9
WTRLO6R01	6	R 1/8"	13	7	25,2	19	12	11,5
WTRLO6R02		R 1/4"	13	9,5	28,2	19	14	16,5
WTRLO6R03		R 3/8"	13	10,5	29,7	19	17	22,6
WTRLO6R04		R 1/2"	13	13,5	33,2	19	21	35,9
WTRLO8R01	8	R 1/8"	15,1	7	26,5	22,8	14	17,6
WTRLO8R02		R 1/4"	15,1	9,5	29	22,8	14	17,7
WTRLO8R03		R 3/8"	15,1	10,5	30,5	22,8	17	25,3
WTRLO8R04		R 1/2"	15,1	13,5	34	22,8	21	38,2
WTRL10R01	10	R 1/8"	18,8	7	29,5	26,3	17	30,7
WTRL10R02		R 1/4"	18,8	9,5	32	26,3	17	31,4
WTRL10R03		R 3/8"	18,8	10,5	33	26,3	17	30,8
WTRL10R04		R 1/2"	18,8	13,5	36,5	26,3	21	47,3
WTRL12R02	12	R 1/4"	21,5	9,5	35,5	29,6	20	44,3
WTRL12R03		R 3/8"	21,5	10,5	36,5	29,6	20	46,7
WTRL12R04		R 1/2"	21,5	13,5	39,5	29,6	21	51,2
WTRL14R03	14	R 3/8"	23,2	10,5	41,5	31,7	21	53
WTRL14R04		R 1/2"	23,2	13,5	45,5	31,7	24	62
WTRL16R03	16	R 3/8"	26	10,5	43	33	24	67,6
WTRL16R04		R 1/2"	26	13,5	46	33	24	72,8

**WTRL-G**

## Swivel male elbow BSPP &amp; metric thread nickel-plated

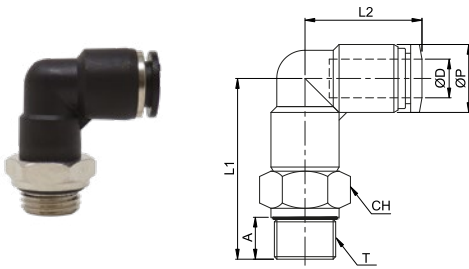

CODE	ØD	T	ØP	A	L1	L2	CH	g
WTRL04M5	4	M5x0,8	11,1	3,8	17,3	17,5	8	5,1
WTRL04M6		M6x1	11,1	4,5	18	17,5	8	5,3
WTRL04G01		G 1/8"	11,1	5	24	17,5	14	11,8
WTRL04G02		G 1/4"	11,1	5,8	25,3	17,5	17	17,9
WTRL06M5	6	M5x0,8	13	3,8	17,3	19	8	5,8
WTRL06M6		M6x1	13	4,5	18	19	8	6
WTRL06G01		G 1/8"	13	5	25,2	19	14	14,6
WTRL06G02		G 1/4"	13	5,8	26,5	19	17	17,5
WTRL06G03		G 3/8"	13	6,8	28	19	20	24,4
WTRL06G04	G 1/2"	13	8	29,2	19	24	38,4	
WTRL08G01	8	G 1/8"	15,1	5	26	22,8	14	17,5
WTRL08G02		G 1/4"	15,1	5,8	27,3	22,8	17	20,5
WTRL08G03		G 3/8"	15,1	6,8	28,8	22,8	20	26,6
WTRL08G04		G 1/2"	15,1	8	30	22,8	24	36,8
WTRL10G01	10	G 1/8"	18,8	5	29	26,3	17	31,2
WTRL10G02		G 1/4"	18,8	5,8	29,8	26,3	17	30,5
WTRL10G03		G 3/8"	18,8	6,8	31,3	26,3	20	34,6
WTRL10G04		G 1/2"	18,8	8	33,5	26,3	24	47,3
WTRL12G02	12	G 1/4"	21,5	5,8	33,8	29,6	20	43,9
WTRL12G03		G 3/8"	21,5	6,8	34,8	29,6	20	44,5
WTRL12G04		G 1/2"	21,5	8	36,5	29,6	24	51,8
WTRL14G03	14	G 3/8"	23,2	6,8	39,8	31,7	21	52
WTRL14G04		G 1/2"	23,2	8	41,5	31,7	24	61
WTRL16G03	16	G 3/8"	26	6,8	40,8	33	24	64
WTRL16G04		G 1/2"	26	8	42	33	24	66,5

**WTRLL-R**

Long swivel male elbow BSPT thread nickel-plated

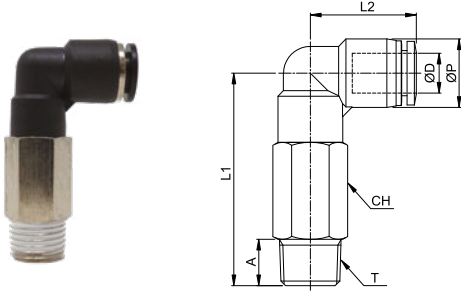

CODE	ØD	T	ØP	A	L1	L2	CH	g
WTRLL04R01	4	R 1/8"	11,1	7	35,5	17,5	10	14,2
WTRLL04R02		R 1/4"	11,1	9,5	39	17,5	14	26,2
WTRLL06R01	6	R 1/8"	13	7	39,2	19	12	22
WTRLL06R02		R 1/4"	13	9,5	42,2	19	14	29,2
WTRLL06R03		R 3/8"	13	10,5	43,7	19	17	39,4
WTRLL06R04		R 1/2"	13	13,5	47,2	19	21	62,9
WTRLL08R01	8	R 1/8"	15,1	7	41,8	22,8	14	34,6
WTRLL08R02		R 1/4"	15,1	9,5	44,3	22,8	14	33,1
WTRLL08R03		R 3/8"	15,1	10,5	45,8	22,8	17	45,6
WTRLL08R04		R 1/2"	15,1	13,5	49,3	22,8	21	70,1
WTRLL10R01	10	R 1/8"	18,8	7	49,5	26,3	17	61,2
WTRLL10R02		R 1/4"	18,8	9,5	52	26,3	17	62,5
WTRLL10R03		R 3/8"	18,8	10,5	53	26,3	17	56,7
WTRLL10R04		R 1/2"	18,8	13,5	56,5	26,3	21	87,2
WTRLL12R02	12	R 1/4"	21,5	9,5	58,5	29,6	20	86,7
WTRLL12R03		R 3/8"	21,5	10,5	59,5	29,6	20	100,7
WTRLL12R04		R 1/2"	21,5	13,5	62,5	29,6	21	89,7

**WTRLL-G**

Long swivel male elbow BSPP & metric thread nickel-plated

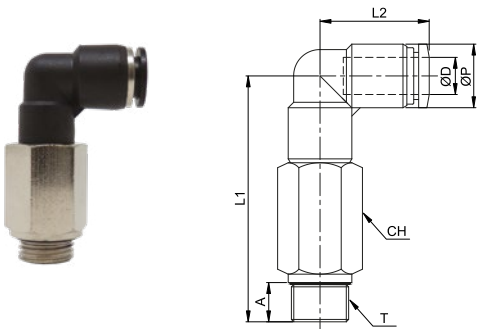

CODE	ØD	T	ØP	A	L1	L2	CH	g
WTRLL04M5	4	M5x0,8	11,1	3,8	29,3	17,5	8	10,4
WTRLL04M6		M6x1	11,1	4,5	30	17,5	8	10,8
WTRLL04G01		G 1/8"	11,1	5	36	17,5	14	25,9
WTRLL04G02		G 1/4"	11,1	5,8	37,3	17,5	17	26,6
WTRLL06M5	6	M5x0,8	13	3,8	31,3	19	8	11,4
WTRLL06M6		M6x1	13	4,5	32	19	8	11,8
WTRLL06G01		G 1/8"	13	5	39,2	19	14	30,5
WTRLL06G02		G 1/4"	13	5,8	40,5	19	17	43,3
WTRLL06G03	6	G 3/8"	13	6,8	42	19	20	57
WTRLL06G04		G 1/2"	13	8	43,2	19	24	91,5
WTRLL08G01		G 1/8"	15,1	5	41,3	22,8	14	35,4
WTRLL08G02		G 1/4"	15,1	5,8	42,6	22,8	17	48
WTRLL08G03	8	G 3/8"	15,1	6,8	44,1	22,8	20	60,3
WTRLL08G04		G 1/2"	15,1	8	45,3	22,8	24	93,7
WTRLL10G01		G 1/8"	18,8	5	49	26,3	17	61,8
WTRLL10G02		G 1/4"	18,8	5,8	49,8	26,3	17	68,7
WTRLL10G03	10	G 3/8"	18,8	6,8	51,3	26,3	20	78,7
WTRLL10G04		G 1/2"	18,8	8	53,5	26,3	24	105,8
WTRLL12G02		G 1/4"	21,5	5,8	56,8	29,6	20	98,1
WTRLL12G03		G 3/8"	21,5	6,8	57,8	29,6	20	101,9
WTRLL12G04	12	G 1/2"	21,5	8	59,5	29,6	24	124,3

**WTRLH-R**

## Swivel male elbow 45° BSPT thread nickel-plated

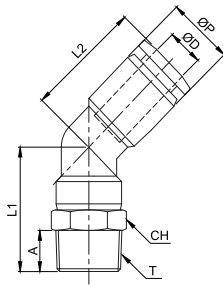

CODE	ØD	T	ØP	A	L1	L2	CH	g
WTRLH04R01	4	R 1/8"	11,1	7	22,2	16,2	10	8
WTRLH04R02		R 1/4"	11,1	9,5	25,7	16,2	14	13,8
WTRLH06R01	6	R 1/8"	13	7	23,9	17,7	12	11
WTRLH06R02		R 1/4"	13	9,5	26,9	17,7	14	16
WTRLH06R03		R 3/8"	13	10,5	28,4	17,7	17	22,2
WTRLH06R04		R 1/2"	13	13,5	31,9	17,7	21	35,4
WTRLH08R01	8	R 1/8"	15,1	7	27,1	20,9	14	17,3
WTRLH08R02		R 1/4"	15,1	9,5	29,6	20,9	14	17,4
WTRLH08R03		R 3/8"	15,1	10,5	31,1	20,9	17	25
WTRLH08R04		R 1/2"	15,1	13,5	34,6	20,9	21	37,9
WTRLH10R01	10	R 1/8"	18,8	7	29,7	22,2	17	30
WTRLH10R02		R 1/4"	18,8	9,5	32,2	22,2	17	30,7
WTRLH10R03		R 3/8"	18,8	10,5	33,2	22,2	17	30,1
WTRLH10R04		R 1/2"	18,8	13,5	36,7	22,2	21	46,6
WTRLH12R02	12	R 1/4"	21,5	9,5	35,2	26,3	20	42,6
WTRLH12R03		R 3/8"	21,5	10,5	36,2	26,3	20	45
WTRLH12R04		R 1/2"	21,5	13,5	39,2	26,3	21	49,5

**WTRLH-G**

## Swivel male elbow 45° BSPP &amp; metric thread nickel-plated

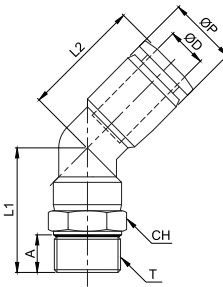

CODE	ØD	T	ØP	A	L1	L2	CH	g
WTRLH04M5	4	M5x0,8	11,1	3,8	20	16,2	10	8,1
WTRLH04M6		M6x1	11,1	4,5	20,7	16,2	10	8,3
WTRLH04G01		G 1/8"	11,1	5	22,7	16,2	14	11,7
WTRLH04G02		G 1/4"	11,1	5,8	24	16,2	17	17,8
WTRLH06M5	6	M5x0,8	13	3,8	21,7	17,7	12	10,8
WTRLH06M6		M6x1	13	4,5	22,4	17,7	12	11,5
WTRLH06G01		G 1/8"	13	5	23,9	17,7	14	14,2
WTRLH06G02		G 1/4"	13	5,8	25,2	17,7	17	17,5
WTRLH06G03	6	G 3/8"	13	6,8	26,7	17,7	20	24
WTRLH06G04		G 1/2"	13	8	27,9	17,7	24	38
WTRLH08G01	8	G 1/8"	15,1	5	26,6	20,9	14	17,2
WTRLH08G02		G 1/4"	15,1	5,8	27,9	20,9	17	20,2
WTRLH08G03		G 3/8"	15,1	6,8	29,4	20,9	20	26,3
WTRLH08G04		G 1/2"	15,1	8	30,6	20,9	24	36,5
WTRLH10G01	10	G 1/8"	18,8	5	29,2	22,2	17	30,6
WTRLH10G02		G 1/4"	18,8	5,8	30	22,2	17	29,9
WTRLH10G03		G 3/8"	18,8	6,8	31,5	22,2	20	34
WTRLH10G04		G 1/2"	18,8	8	33,7	22,2	24	46,7
WTRLH12G02	12	G 1/4"	21,5	5,8	33,5	26,3	20	42,4
WTRLH12G03		G 3/8"	21,5	6,8	34,5	26,3	20	43
WTRLH12G04		G 1/2"	21,5	8	36,2	26,3	24	50,3



**WTRLF-G**

Swivel female elbow BSPP & metric thread nickel-plated

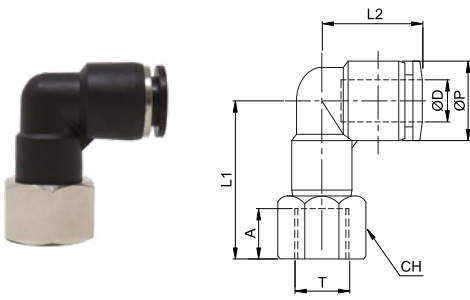

CODE	ØD	T	ØP	A	L1	L2	CH	g
WTRLF04M5	4	M5x0,8	11,1	4,5	19,5	17,5	10	7,4
WTRLF04M6		M6x1	11,1	5	20	17,5	10	7,2
WTRLF04G01		G 1/8"	11,1	7	23	17,5	14	13,9
WTRLF04G02		G 1/4"	11,1	9	25	17,5	17	18,2
WTRLF06M5	6	M5x0,8	13	4,5	20,7	19	12	10,6
WTRLF06M6		M6x1	13	5	21,2	19	12	10,4
WTRLF06G01		G 1/8"	13	7	24,4	19	14	16,4
WTRLF06G02		G 1/4"	13	9	26,4	19	17	21,3
WTRLF06G03	8	G 3/8"	13	10	27,7	19	19	30
WTRLF08G01		G 1/8"	15,1	7	24,8	22,8	14	19,4
WTRLF08G02		G 1/4"	15,1	9	27	22,8	17	24,1
WTRLF08G03		G 3/8"	15,1	10	28,5	22,8	19	32,4
WTRLF08G04	10	G 1/2"	15,1	12	30,5	22,8	24	41,6
WTRLF10G01		G 1/8"	18,8	7	23	26,3	17	27,7
WTRLF10G02		G 1/4"	18,8	9	29,5	26,3	17	33,8
WTRLF10G03		G 3/8"	18,8	10	31	26,3	19	34,3
WTRLF10G04	12	G 1/2"	18,8	12	33,5	26,3	24	51,2
WTRLF12G02		G 1/4"	21,5	9	26	29,6	21	36,7
WTRLF12G03		G 3/8"	21,5	10	34	29,6	21	49,2
WTRLF12G04		G 1/2"	21,5	12	36,5	29,6	24	54,7

**WTRLM**

Bulkhead swivel elbow nickel-plated

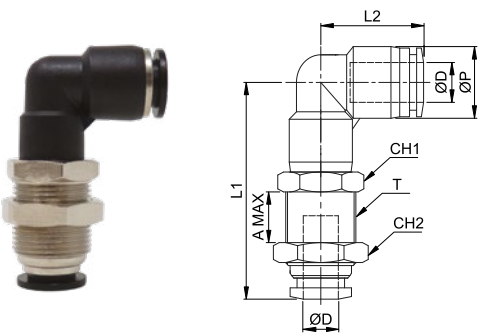

CODE	ØD	T	ØP	A MAX	L1	L2	CH1	CH2	g
WTRLM04	4	M12x1	11,1	4,1	28,5	17,5	14	14	15
WTRLM06	6	M14x1	13	5,7	34,1	19	17	17	27,2
WTRLM08	8	M16x1	15,1	7,2	40,6	22,8	17	19	38
WTRLM10	10	M20x1	18,8	7,4	45,5	26,3	21	24	55
WTRLM12	12	M22x1	21,5	9,7	51,6	29,6	24	27	85

**WTRH-R**

## Swivel male banjo elbow BSPT thread nickel-plated

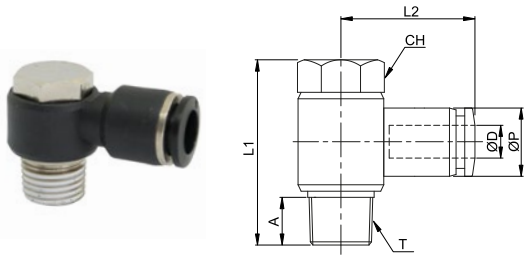

CODE	ØD	T	ØP	A	L1	L2	CH	g
WTRH04R01	4	R 1/8"	11,1	7	23	22,3	10	10,5
WTRH04R02		R 1/4"	11,1	9,5	26,3	24	14	21,9
WTRH06R01	6	R 1/8"	13	7	23	23,1	10	11
WTRH06R02		R 1/4"	13	9,5	26,3	25,1	14	22,5
WTRH06R03		R 3/8"	13	10,5	31,9	26,8	19	37,8
WTRH08R01	8	R 1/8"	15,1	7	23	25,6	10	11,8
WTRH08R02		R 1/4"	15,1	9,5	26,3	28,6	14	23,3
WTRH08R03		R 3/8"	15,1	10,5	31,9	29,6	19	38,4
WTRH08R04		R 1/2"	15,1	13,5	38,6	32,6	24	75,4
WTRH10R02	10	R 1/4"	18,8	9,5	26,3	31	14	26,7
WTRH10R03		R 3/8"	18,8	10,5	31,9	31,6	19	41,8
WTRH10R04		R 1/2"	18,8	13,5	38,6	34,6	24	78,8
WTRH12R02	12	R 1/4"	21,5	9,5	26,3	33,5	14	28,2
WTRH12R03		R 3/8"	21,5	10,5	31,9	35,6	19	43,4
WTRH12R04		R 1/2"	21,5	13,5	38,6	36,6	24	80,3

**WTRH-G**

## Swivel male banjo elbow BSPP &amp; metric thread nickel-plated

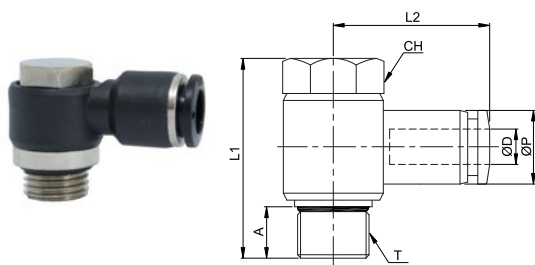

CODE	ØD	T	ØP	A	L1	L2	CH	g
WTRH04M5	4	M5x0,8	11,1	4	18	20	8	6,6
WTRH04M6		M6x1	11,1	4,5	18,5	20	8	11,8
WTRH04G01		G 1/8"	11,1	5	22,5	22,3	10	11,5
WTRH06M5	6	M5x0,8	13	4	18	21,9	8	7,2
WTRH06M6		M6x1	13	4,5	18,5	21,9	8	12,4
WTRH06G01		G 1/8"	13	5	22,5	23,1	10	12
WTRH06G02		G 1/4"	13	5,8	26,2	25,1	14	23
WTRH08G01	8	G 1/8"	15,1	5	22,5	25,6	10	12,8
WTRH08G02		G 1/4"	15,1	5,8	26,2	28,6	14	23,8
WTRH08G03		G 3/8"	15,1	6,8	31,7	29,6	19	40,9
WTRH10G02	10	G 1/4"	18,8	5,8	26,2	31	14	27,2
WTRH10G03		G 3/8"	18,8	6,8	31,7	31,6	19	44,3
WTRH12G03	12	G 3/8"	21,5	6,8	31,7	35,6	19	45,9
WTRH12G04		G 1/2"	21,5	8	37,1	36,6	24	79,3

**WTRHF-R**

Swivel female banjo elbow BSPT thread nickel-plated

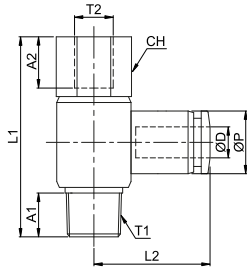
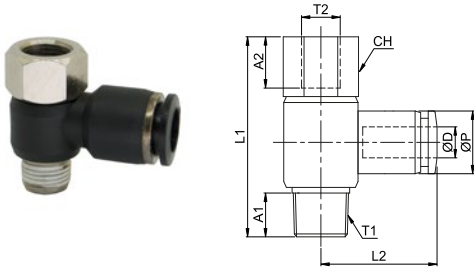

CODE	ØD	T1	T2	ØP	A1	A2	L1	L2	CH	g
WTRHF04R01	4	R 1/8"	G 1/8"	11,1	7	7	29	22,3	14	16,4
WTRHF04R02		R 1/4"	G 1/4"	11,1	9,5	9	33,3	24,1	17	27,4
WTRHF06R01	6	R 1/8"	G 1/8"	13	7	7	29	23,1	14	17
WTRHF06R02		R 1/4"	G 1/4"	13	9,5	9	33,3	25,1	17	28
WTRHF06R03		R 3/8"	G 3/8"	13	10,5	10	39,9	26,8	19	44,8
WTRHF08R01	8	R 1/8"	G 1/8"	15,1	7	7	29	25,6	14	17,8
WTRHF08R02		R 1/4"	G 1/4"	15,1	9,5	9	33,3	28,6	17	28,8
WTRHF08R03		R 3/8"	G 3/8"	15,1	10,5	10	39,9	29,6	19	45,4
WTRHF08R04		R 1/2"	G 1/2"	15,1	13,5	12	46,5	32,6	24	71,9
WTRHF10R02	10	R 1/4"	G 1/4"	18,8	9,5	9	33,3	31	17	32,2
WTRHF10R03		R 3/8"	G 3/8"	18,8	10,5	10	39,9	31,6	19	48,8
WTRHF10R04		R 1/2"	G 1/2"	18,8	13,5	12	46,5	34,6	24	75,3
WTRHF12R02	12	R 1/4"	G 1/4"	21,5	9,5	9	33,3	33,5	17	33,7
WTRHF12R03		R 3/8"	G 3/8"	21,5	10,5	10	39,9	35,6	19	50,4
WTRHF12R04		R 1/2"	G 1/2"	21,5	13,5	12	46,5	36,6	24	76,8

**WTRHF-G**

Swivel female banjo elbow BSPP & metric thread nickel-plated

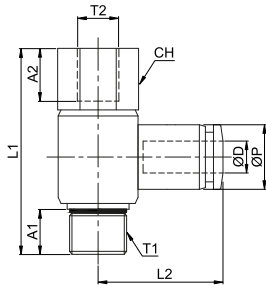
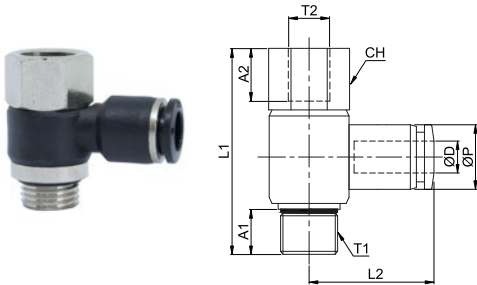

CODE	ØD	T1	T2	ØP	A1	A2	L1	L2	CH	g
WTRHF04M5	4	M5x0,8	M5x0,8	11,1	4	5,5	20,5	20	10	8,3
WTRHF04M6		M6x1	M6x1	11,1	4,5	6	21	20	10	8,3
WTRHF04G01		G 1/8"	G 1/8"	11,1	5,5	7	30	22,3	14	18,4
WTRHF06M5	6	M5x0,8	M5x0,8	13	4	5,5	20,5	21,9	10	8,9
WTRHF06M6		M6x1	M6x1	13	4,5	6	21	21,9	10	8,9
WTRHF06G01		G 1/8"	G 1/8"	13	5,5	7	30	23,1	14	19
WTRHF06G02		G 1/4"	G 1/4"	13	6,5	9	33,7	25,1	17	30,5
WTRHF08G01	8	G 1/8"	G 1/8"	15,1	5,5	7	30	25,6	14	19,8
WTRHF08G02		G 1/4"	G 1/4"	15,1	6,5	9	33,7	28,6	17	31,3
WTRHF08G03		G 3/8"	G 3/8"	15,1	7,5	10	39,7	29,6	19	47,9
WTRHF10G02	10	G 1/4"	G 1/4"	18,8	6,5	9	33,7	31,1	17	34,7
WTRHF10G03		G 3/8"	G 3/8"	18,8	7,5	10	39,7	31,6	19	51,3
WTRHF12G03	12	G 3/8"	G 3/8"	21,5	7,5	10	39,7	35,6	19	52,9
WTRHF12G04		G 1/2"	G 1/2"	21,5	9	12	45	36,6	24	77,3

## WTRT-R

## Swivel male central tee BSPT thread nickel-plated

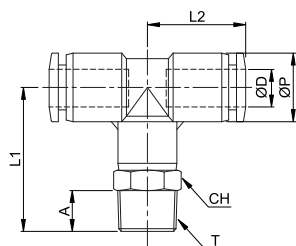

CODE	ØD	T	ØP	A	L1	L2	CH	g
WTRT04R01	4	R 1/8"	11,1	7	24,5	18,5	10	10,5
WTRT04R02		R 1/4"	11,1	9,5	28	18,5	14	16,3
WTRT06R01	6	R 1/8"	13	7	25,5	19,3	12	14,1
WTRT06R02		R 1/4"	13	9,5	28,5	19,3	14	19,1
WTRT06R03		R 3/8"	13	10,5	30	19,3	17	25,2
WTRT06R04		R 1/2"	13	13,5	33,5	19,3	21	38,5
WTRT08R01	8	R 1/8"	15,1	7	29	22,7	14	20,9
WTRT08R02		R 1/4"	15,1	9,5	31,4	22,7	14	21
WTRT08R03		R 3/8"	15,1	10,5	32,9	22,7	17	28,6
WTRT08R04		R 1/2"	15,1	13,5	36,4	22,7	21	41,5
WTRT10R01	10	R 1/8"	18,8	7	34,5	27	17	37,9
WTRT10R02		R 1/4"	18,8	9,5	37	27	17	38,6
WTRT10R03		R 3/8"	18,8	10,5	38	27	17	38
WTRT10R04		R 1/2"	18,8	13,5	41,5	27	21	54,5
WTRT12R02	12	R 1/4"	21,5	9,5	38,5	29,6	20	52,8
WTRT12R03		R 3/8"	21,5	10,5	39,5	29,6	20	55,2
WTRT12R04		R 1/2"	21,5	13,5	42,5	29,6	21	59,7
WTRT16R03	16	R 3/8"	26	10,5	43	33	24	81
WTRT16R04		R 1/2"	26	13,5	46	33	24	85,5

## WTRT-G

## Swivel male central tee BSPP &amp; metric thread nickel-plated

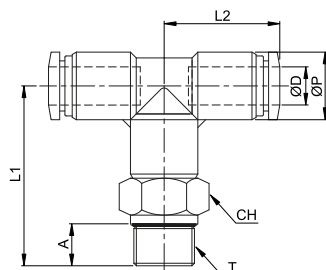

CODE	ØD	T	ØP	A	L1	L2	CH	g	
WTRT04M5	4	M5x0,8	11,1	3,8	22,3	18,5	10	10,6	
WTRT04M6		M6x1	11,1	4,5	23	18,5	10	10,8	
WTRT04G01		G 1/8"	11,1	5	25	18,5	14	14,2	
WTRT04G02		G 1/4"	11,1	5,8	26,3	18,5	17	20,3	
WTRT06M5	6	M5x0,8	13	3,8	23,3	19,3	12	13,9	
WTRT06M6		M6x1	13	4,5	24	19,3	12	14,6	
WTRT06G01		G 1/8"	13	5	25,5	19,3	14	17,2	
WTRT06G02		G 1/4"	13	5,8	26,8	19,3	17	20,5	
WTRT06G03	6	G 3/8"	13	6,8	28,3	19,3	20	27	
WTRT06G04		G 1/2"	13	8	29,5	19,3	24	41	
WTRT08G01		8	G 1/8"	15,1	5	28,4	22,7	14	20,8
WTRT08G02			G 1/4"	15,1	5,8	29,7	22,7	17	23,8
WTRT08G03	G 3/8"		15,1	6,8	31,2	22,7	20	29,9	
WTRT08G04	G 1/2"		15,1	8	32,4	22,7	24	40,1	
WTRT10G01	10	G 1/8"	18,8	5	34	27	17	38,4	
WTRT10G02		G 1/4"	18,8	5,8	34,8	27	17	37,7	
WTRT10G03		G 3/8"	18,8	6,8	36,3	27	20	41,8	
WTRT10G04		G 1/2"	18,8	8	38,5	27	24	54,5	
WTRT12G02	12	G 1/4"	21,5	5,8	36,8	29,6	21	52,4	
WTRT12G03		G 3/8"	21,5	6,8	37,8	29,6	21	53	
WTRT12G04		G 1/2"	21,5	8	39,5	29,6	24	60,3	
WTRT14G03	14	G 3/8"	23,2	6,8	39,8	31,7	21	61	
WTRT14G04		G 1/2"	23,2	8	41,5	31,7	24	69	
WTRT16G03	16	G 3/8"	26	6,8	40,8	33	24	76,6	
WTRT16G04		G 1/2"	26	8	42	33	24	79,4	

**WTRST-R**

Swivel male lateral tee BSPT thread nickel-plated

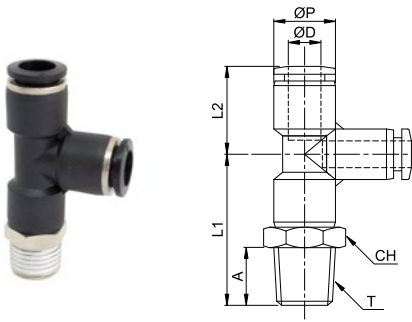

CODE	ØD	T	ØP	A	L1	L2	CH	g
WTRST04R01	4	R 1/8"	11,1	7	24,5	18,5	10	10,5
WTRST04R02		R 1/4"	11,1	9,5	28	18,5	14	16,3
WTRST06R01	6	R 1/8"	13	7	25,5	19,3	12	14,1
WTRST06R02		R 1/4"	13	9,5	28,5	19,3	14	19,1
WTRST06R03		R 3/8"	13	10,5	30	19,3	17	25,2
WTRST06R04	6	R 1/2"	13	13,5	33,5	19,3	21	38,5
WTRST08R01	8	R 1/8"	15,1	7	29	22,7	14	20,9
WTRST08R02		R 1/4"	15,1	9,5	31,4	22,7	14	21
WTRST08R03		R 3/8"	15,1	10,5	32,9	22,7	17	28,6
WTRST08R04		R 1/2"	15,1	13,5	36,4	22,7	21	41,5
WTRST10R01	10	R 1/8"	18,8	7	34,5	27	17	37,9
WTRST10R02		R 1/4"	18,8	9,5	37	27	17	38,6
WTRST10R03		R 3/8"	18,8	10,5	38	27	17	38
WTRST10R04		R 1/2"	18,8	13,5	41,5	27	21	54,5
WTRST12R02	12	R 1/4"	21,5	9,5	38,5	29,6	20	52,8
WTRST12R03		R 3/8"	21,5	10,5	39,5	29,6	20	55,2
WTRST12R04		R 1/2"	21,5	13,5	42,5	29,6	21	59,7

**WTRST-G**

Swivel male lateral tee BSPP & metric thread nickel-plated

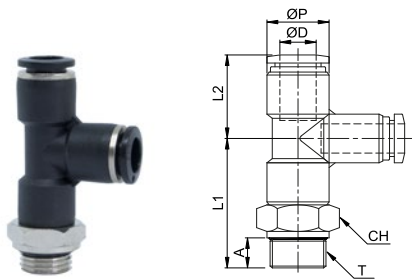

CODE	ØD	T	ØP	A	L1	L2	CH	g
WTRST04M5	4	M5x0,8	11,1	3,8	22,3	18,5	10	10,8
WTRST04M6		M6x1	11,1	4,5	23	18,5	10	11
WTRST04G01		G 1/8"	11,1	5	25	18,5	14	14,5
WTRST04G02		G 1/4"	11,1	5,8	26,3	18,5	17	20,6
WTRST06M5	6	M5x0,8	13	3,8	23,3	19,3	12	14,5
WTRST06M6		M6x1	13	4,5	24	19,3	12	15,1
WTRST06G01		G 1/8"	13	5	25,5	19,3	14	17,7
WTRST06G02		G 1/4"	13	5,8	26,8	19,3	17	21
WTRST06G03	6	G 3/8"	13	6,8	28,3	19,3	20	27,5
WTRST06G04	G 1/2"	13	8	29,5	19,3	24	41,5	
WTRST08G01	8	G 1/8"	15,1	5	28,4	22,7	14	20,9
WTRST08G02		G 1/4"	15,1	5,8	29,7	22,7	17	23,9
WTRST08G03		G 3/8"	15,1	6,8	31,2	22,7	20	30
WTRST08G04		G 1/2"	15,1	8	32,4	22,7	24	40,2
WTRST10G01	10	G 1/8"	18,8	5	34	27	17	38,8
WTRST10G02		G 1/4"	18,8	5,8	34,8	27	17	38,1
WTRST10G03		G 3/8"	18,8	6,8	36,3	27	20	42,2
WTRST10G04		G 1/2"	18,8	8	38,5	27	24	54,9
WTRST12G02	12	G 1/4"	21,5	5,8	36,8	29,6	21	53,2
WTRST12G03		G 3/8"	21,5	6,8	37,8	29,6	21	53,8
WTRST12G04		G 1/2"	21,5	8	39,5	29,6	24	61,1

## WTRWT-R

## Swivel male Y BSPT thread nickel-plated

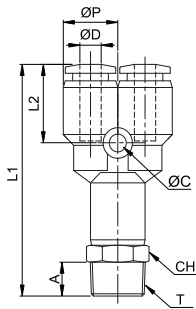

CODE	ØD	T	ØP	ØC	A	L1	L2	CH	g
WTRWT04R01	4	R 1/8"	11,1	3,2	7	41,5	14	10	10,7
WTRWT04R02		R 1/4"	11,1	3,2	9,5	45	14	14	16,6
WTRWT06R01	6	R 1/8"	13	3,2	7	43,3	14,8	12	14,6
WTRWT06R02		R 1/4"	13	3,2	9,5	46,3	14,8	14	19,6
WTRWT06R03		R 3/8"	13	3,2	10,5	47,8	14,8	17	25,8
WTRWT06R04	6	R 1/2"	13	3,2	13,5	51,3	14,8	21	39
WTRWT08R01	8	R 1/8"	15,1	3,2	7	46,6	18,2	14	21
WTRWT08R02		R 1/4"	15,1	3,2	9,5	49,1	18,2	14	21,1
WTRWT08R03		R 3/8"	15,1	3,2	10,5	50,6	18,2	17	28,7
WTRWT08R04		R 1/2"	15,1	3,2	13,5	54,1	18,2	21	41,6
WTRWT10R01	10	R 1/8"	18,8	4,2	7	54,6	19,5	17	38,3
WTRWT10R02		R 1/4"	18,8	4,2	9,5	57,1	19,5	17	39
WTRWT10R03		R 3/8"	18,8	4,2	10,5	58,1	19,5	17	38,4
WTRWT10R04		R 1/2"	18,8	4,2	13,5	61,6	19,5	21	54,9
WTRWT12R02	12	R 1/4"	21,5	4,3	9,5	62,1	21,6	21	53,6
WTRWT12R03		R 3/8"	21,5	4,3	10,5	63,1	21,6	21	46
WTRWT12R04		R 1/2"	21,5	4,3	13,5	66,1	21,6	21	60,5

## WTRWT-G

## Swivel male Y BSPP &amp; metric thread nickel-plated

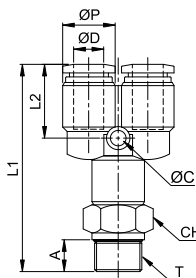

CODE	ØD	T	ØP	ØC	A	L1	L2	CH	g
WTRWT04M5	4	M5x0,8	11,1	3,2	3,8	39,3	14	10	10,8
WTRWT04M6		M6x1	11,1	3,2	4,5	40	14	10	11
WTRWT04G01		G 1/8"	11,1	3,2	5	42	14	14	14,5
WTRWT04G02		G 1/4"	11,1	3,2	5,8	43,3	14	17	20,6
WTRWT06M5	6	M5x0,8	13	3,2	3,8	41,1	14,8	12	14,5
WTRWT06M6		M6x1	13	3,2	4,5	41,8	14,8	12	15,1
WTRWT06G01		G 1/8"	13	3,2	5	43,3	14,8	14	17,7
WTRWT06G02		G 1/4"	13	3,2	5,8	44,6	14,8	17	21
WTRWT06G03	6	G 3/8"	13	3,2	6,8	46,1	14,8	20	27,5
WTRWT06G04	6	G 1/2"	13	3,2	8	47,3	14,8	24	41,5
WTRWT08G01	8	G 1/8"	15,1	3,2	5	46,1	18,2	14	20,9
WTRWT08G02		G 1/4"	15,1	3,2	5,8	47,4	18,2	17	23,9
WTRWT08G03		G 3/8"	15,1	3,2	6,8	48,9	18,2	20	30
WTRWT08G04		G 1/2"	15,1	3,2	8	50,1	18,2	24	40,2
WTRWT10G01	10	G 1/8"	18,8	4,2	5	54,1	19,5	17	38,8
WTRWT10G02		G 1/4"	18,8	4,2	5,8	54,9	19,5	17	38,1
WTRWT10G03		G 3/8"	18,8	4,2	6,8	56,4	19,5	20	42,2
WTRWT10G04		G 1/2"	18,8	4,2	8	58,6	19,5	24	54,9
WTRWT12G02	12	G 1/4"	21,5	4,3	5,8	60,4	21,6	21	53,2
WTRWT12G03		G 3/8"	21,5	4,3	6,8	61,4	21,6	21	53,8
WTRWT12G04		G 1/2"	21,5	4,3	8	63,1	21,6	24	61,1

### WTRKD-R

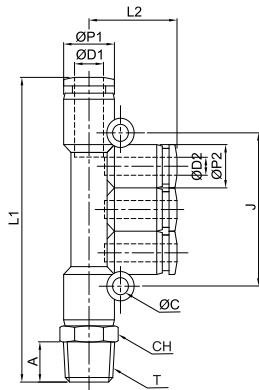

Swivel multi-tee lateral male connector BSPT thread nickel-plated

CODE	ØD1	ØD2	T	ØP1	ØP2	ØC	A	L1	L2	J	CH	g
WTRKD0604R01	6	4	R 1/8"	13	11,1	3,2	7	63,8	19	36	12	17,4
WTRKD0804R02	8	4	R 1/4"	15,1	11,1	3,2	9,5	71,3	20	42	14	23,1
WTRKD0806R02	8	6	R 1/4"	15,1	13	3,2	9,5	71,3	20,3	42	14	24,2
WTRKD1008R03	10	8	R 3/8"	18,8	15,1	4,2	10,5	91	24,3	48	17	40,2

### WTRKD-G

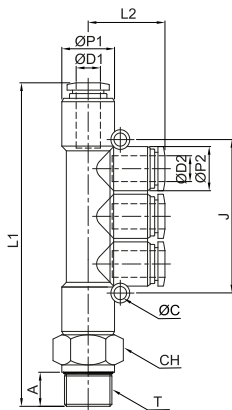

Swivel multi-tee lateral male connector BSPP thread nickel-plated

CODE	ØD1	ØD2	T	ØP1	ØP2	ØC	A	L1	L2	J	CH	g
WTRKD0604G01	6	4	G 1/8"	13	11,1	3,2	5	63,8	19	36	14	20,5
WTRKD0804G02	8	4	G 1/4"	15,1	11,1	3,2	5,8	69,6	20	42	17	26
WTRKD0806G02	8	6	G 1/4"	15,1	15,1	3,2	5,8	69,6	20,3	42	17	27
WTRKD1008G03	10	8	G 3/8"	18,8	15,1	4,2	6,8	89,3	24,3	48	20	44

## WTRUC

## Union connector

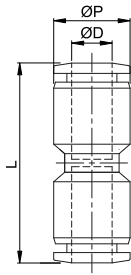

CODE	ØD	ØP	L	g
WTRUC0400	4	11,1	33	4,2
WTRUC0500	5	12,8	35,2	5
WTRUC0600	6	13	35,2	5,2
WTRUC0700	7	14,5	39,1	7
WTRUC0800	8	15,1	39,1	6,8
WTRUC0900	9	18,8	45,2	14
WTRUC1000	10	18,8	48,4	14
WTRUC1100	11	21,2	49,2	17
WTRUC1200	12	21,5	49,2	16,4
WTRUC1400	14	23,2	48,4	18
WTRUC1500	15	25,8	51	25
WTRUC1600	16	26	51	24,5

## WTRG

## Reduced union connector

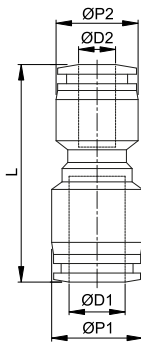

CODE	ØD1	ØD2	ØP1	ØP2	L	g
WTRG0604	6	4	13	11,1	33,6	5,2
WTRG0804	8	4	15,1	11,1	34	5,8
WTRG0805	8	5	15,1	12,8	35,5	6
WTRG0806	8	6	15,1	13	36,1	6,8
WTRG1007	10	7	18,8	14,5	41,8	10
WTRG1008	10	8	18,8	15,1	41,8	12,7
WTRG1207	12	7	21,5	14,5	46,9	13
WTRG1208	12	8	21,5	15,1	46,9	14,1
WTRG1210	12	10	21,5	18,8	47,7	16,6
WTRG1410	14	10	23,2	18,8	48,3	17
WTRG1412	14	12	23,2	21,5	48,3	17
WTRG1610	16	10	26	18,8	48,5	24,3
WTRG1612	16	12	26	21,5	50,1	26
WTRG1614	16	14	26	23,2	50	28

## WTRUL

## Union elbow

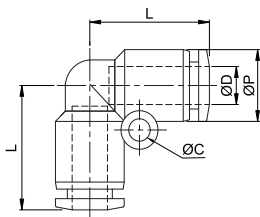

CODE	ØD	ØP	ØC	L	g
WTRUL0400	4	11,1	3,2	17,5	4,2
WTRUL0600	6	13	3,2	19	5,5
WTRUL0800	8	15,1	3,2	22,8	7,3
WTRUL1000	10	18,8	4,2	26,3	14,3
WTRUL1200	12	21,5	4,3	29,6	18,2
WTRUL1400	14	23,2	5,1	31,7	23
WTRUL1600	16	26	5,1	33	27



**WTRUT**

Union tee

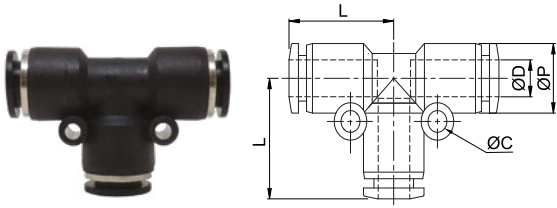

CODE	ØD	ØP	ØC	L	g
WTRUT0400	4	11,1	3,2	18,5	6,5
WTRUT0600	6	13	3,2	19,3	8,1
WTRUT0800	8	15,1	3,2	22,7	10,6
WTRUT1000	10	18,8	4,2	27	21,4
WTRUT1200	12	21,5	4,3	29,6	26,7
WTRUT1400	14	23,2	5,1	31,7	31
WTRUT1600	16	26	5,1	33	39,7

**WTRGT**

Reduced union tee

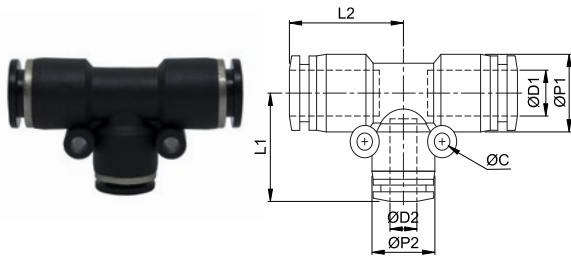

CODE	ØD1	ØD2	ØP1	ØP2	ØC	L1	L2	g
WTRGT0604	6	4	13	11,1	3,2	19,5	19,3	8,1
WTRGT0804	8	4	15,1	11,1	3,2	19,8	22,8	9,8
WTRGT0806	8	6	15,1	13	3,2	20,3	22,8	10,6
WTRGT1008	10	8	18,8	15,1	4,2	24,8	27	20,2
WTRGT1210	12	10	21,5	18,8	4,2	28,5	29,6	26,9
WTRGT1612	16	12	26	21,5	5,1	32,1	33	41,9

**WTRY**

Union Y

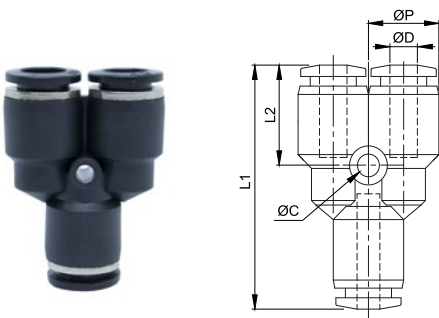

CODE	ØD	ØP	ØC	L1	L2	g
WTRY0400	4	11,1	3,2	35,5	14	6,8
WTRY0600	6	13	3,2	37,1	14,8	8,6
WTRY0800	8	15,1	3,2	40,4	18,2	10,7
WTRY1000	10	18,8	4,2	47,1	19,5	21,8
WTRY1200	12	21,5	4,2	53,2	21,6	27,5
WTRY1600	16	26	5,1	61	23,5	33,5

**WTRW**

Reduced union Y

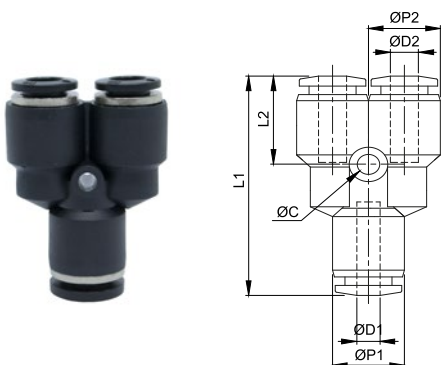

CODE	ØD1	ØD2	ØP1	ØP2	ØC	L1	L2	g
WTRW0604	6	4	13	11,1	3,2	36,8	14,5	9,2
WTRW0806	8	6	15,1	13	3,2	39,9	17,7	11,4
WTRW1008	10	8	18,8	15,1	4,2	47,9	20,3	21,8
WTRW1210	12	10	21,5	18,8	4,2	51,6	20	29,3

## WTRZA

## Union cross

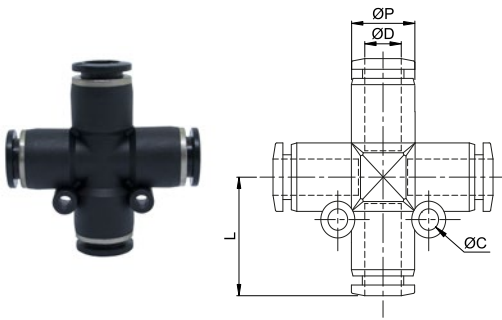

CODE	ØD	ØP	ØC	L	g
WTRZA0400	4	11,1	3,2	17,5	8
WTRZA0600	6	13	3,2	19,3	10,2
WTRZA0800	8	15,1	3,2	22,7	13,6
WTRZA1000	10	18,8	4,2	27	28,2
WTRZA1200	12	21,5	4,3	29,6	34,2

## WTRK

## Union multi-tee

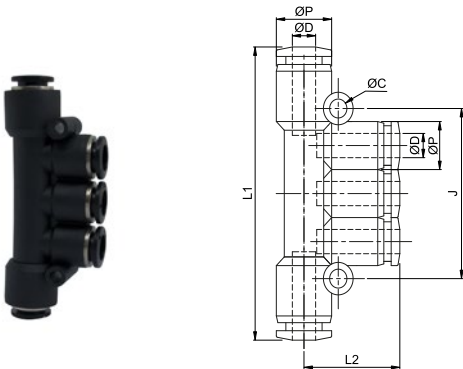

CODE	ØD	ØP	ØC	L1	L2	J	g
WTRK04	4	11,1	3,2	57	19	36	13
WTRK06	6	13	3,2	61,6	20,3	42	17
WTRK08	8	15,1	3,2	81,6	24,3	48	22

## WTRKG

## Reduced union multi-tee

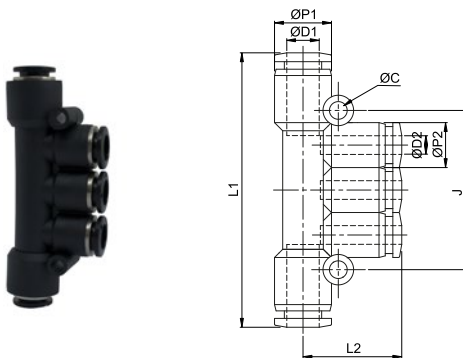

CODE	ØD1	OD2	ØP1	ØP2	ØC	L1	L2	J	g
WTRKG0604	6	4	13	11,1	3,2	57,6	19	36	13
WTRKG0804	8	4	15,1	11,1	3,2	62,6	20	42	16
WTRKG0806	8	6	15,1	13	3,2	62,6	20,3	42	16,6
WTRKG1006	10	6	18,8	13	4,2	80	23,8	48	28
WTRKG1008	10	8	18,8	15,1	4,2	80	24,3	48	30,8

## WTRGJ

## Stem reduction

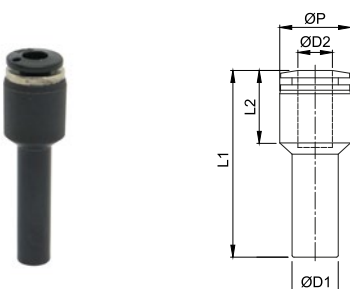

CODE	ØD1	ØD2	ØP	L1	L2	g
WTRGJ0604	6	4	11,1	39,5	14	1,4
WTRGJ0804	8	4	11,1	41,5	14	2,7
WTRGJ0806	8	6	13	41,8	14,3	2
WTRGJ1006	10	6	13	46,8	17,3	3,8
WTRGJ1008	10	8	15,1	47,3	17,8	2,8
WTRGJ1206	12	6	13	51,8	19,3	7,7
WTRGJ1208	12	8	15,1	52,3	19,8	6,4
WTRGJ1210	12	10	18,8	51,5	19	4,2

**WTRLJ**

Elbow with stem

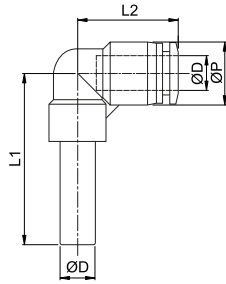

CODE	ØD	ØP	L1	L2	g
WTRLJ0400	4	11,1	33,7	17,5	6,5
WTRLJ0600	6	13	34,9	19	8,1
WTRLJ0800	8	15,1	39,1	22,8	10,6
WTRLJ1000	10	18,8	46,1	26,3	21,4
WTRLJ1200	12	21,5	52,2	29,6	26,7

**WTRLGJ**

Reduced elbow with stem

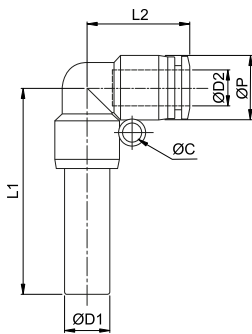

CODE	ØD1	ØD2	ØP	ØP2	ØC	L1	L2	g
WTRLGJ0604	6	4	13	11,1	3,2	33,7	17,5	8,7
WTRLGJ0806	8	6	15,1	13	3,2	38,3	19	13,7
WTRLGJ1008	10	8	18,8	15,1	4,2	46,1	22,8	19,4
WTRLGJ1210	12	10	21,5	18,8	4,2	53,5	26,3	34,6
ENLARGED ELBOW WITH STEM								
WTRLGJ0406	4	6	11,1	13	3,2	33,7	19	8,7

**WTRTJ**

Tee with stem

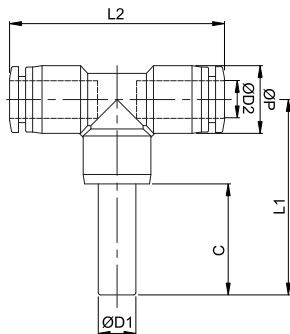

CODE	ØD1	ØD2	ØP	L1	L2	C	g
WTRTJ04	4	4	11,1	34,7	37	20,2	-
WTRTJ06	6	6	13	35,2	38,6	20,2	-
WTRTJ08	8	8	15,1	41,6	45,7	23,6	-
WTRTJ10	10	10	18,8	51,1	57,6	28,1	-
WTRTJ12	12	12	21,5	55,2	58,8	31,2	-

**WTRTGJ**

Reduced tee with stem

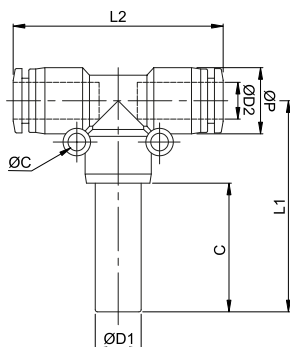

CODE	ØD1	ØD2	ØP	ØC	L1	L2	C	g
WTRTGJ0604	6	4	11,1	3,2	34,7	37	20,2	-
WTRTGJ0806	8	6	13	3,2	38,6	38,6	23,6	-
WTRTGJ1008	10	8	15,1	3,2	46,1	45,7	28,1	-
WTRTGJ1210	12	10	18,8	4,2	54,2	57,6	31,2	-

**WTRYJ**

## Union Y with stem

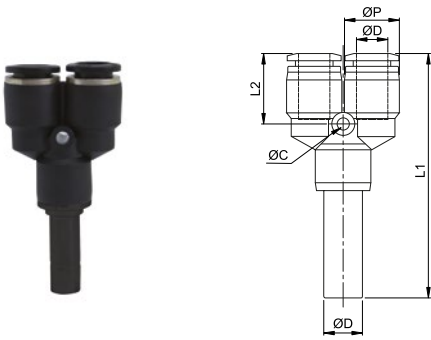

CODE	ØD	ØP	ØC	L1	L2	g
WTRYJ0400	4	11,1	3,2	51,7	14	10,2
WTRYJ0600	6	13	3,2	53	14,8	14,4
WTRYJ0800	8	15,1	3,2	59,3	18,3	20,4
WTRYJ1000	10	18,8	4,2	73	21,3	38,1
WTRYJ1200	12	21,5	4,2	78,6	21,4	49,9

**WTRWJ**

## Reduced union Y with stem

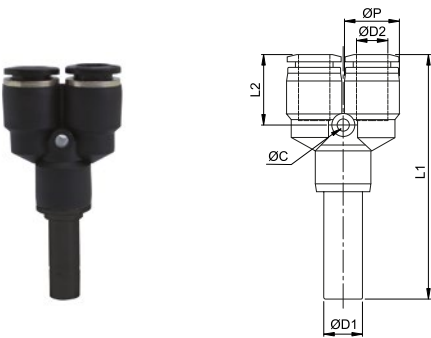

CODE	ØD1	ØD2	ØP	ØC	L1	L2	g
WTRWJ0604	6	4	11,1	3,2	51,7	14	14,5
WTRWJ0806	8	6	13	3,2	53	14,8	20,4
WTRWJ1008	10	8	15,1	4,2	59,3	18,3	35,5
WTRWJ1210	12	10	18,8	4,2	73	21,3	50,5

**WTRKJ**

## Reduced union multi-tee with lateral stem

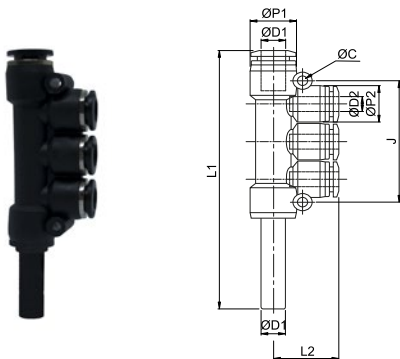

CODE	ØD1	ØD2	ØP1	ØP2	ØC	L1	L2	J	g
WTRKJ0604	6	4	13	11,1	3,2	73,5	19	36	4,2
WTRKJ0804	8	4	15,1	11,1	3,2	81,5	20	42	5,5
WTRKJ0806	8	6	15,1	13	3,2	81,5	20,3	42	7,3
WTRKJ1006	10	6	18,8	13	4,2	104,5	23,8	48	14,3
WTRKJ1008	10	8	18,8	15,1	4,2	105,9	24,3	48	18,2

**WTRPF**

## Female plug

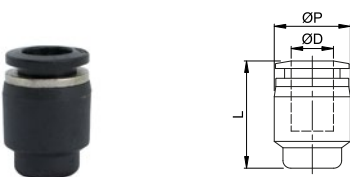

CODE	ØD	ØP	L	g
WTRPF04	4	11,1	17	2,6
WTRPF05	5	12,8	17,3	3,1
WTRPF06	6	13	17,3	3,7
WTRPF07	7	14,5	20,8	3,8
WTRPF08	8	15,1	20,8	4,2
WTRPF10	10	18,8	25,3	5,5
WTRPF12	12	21,5	25,6	9,3
WTRPF14	14	23,2	25,7	12,4
WTRPF15	15	25,8	27	15,3
WTRPF16	16	26	27	17,1

**WTRIJ**

Junction

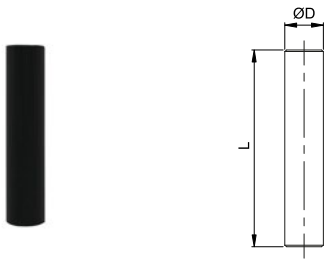

CODE	ØD	L	g
WTRIJ04	4	35	0,4
WTRIJ06	6	37	0,8
WTRIJ08	8	41	1,2
WTRIJ10	10	51	2,7
WTRIJ12	12	54	3,5
WTRIJ16	16	58	5,3

**WTRIG**

Reduced junction

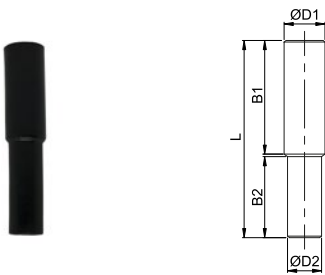

CODE	ØD1	ØD2	B1	B2	L	g
WTRIG0604	6	4	18	17	36	0,6
WTRIG0806	8	6	20	18	39	1
WTRIG1008	10	8	25	20	46	1,9
WTRIG1210	12	10	27	26	54	3,2
WTRIG1612	16	12	28	28	56	4,8

**WTRP**

Male plug

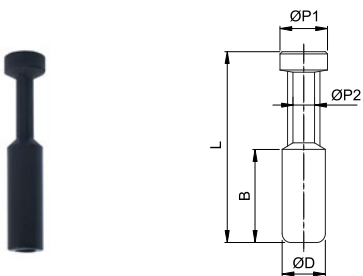

CODE	ØD	ØP1	ØP2	B	L	g
WTRP04	4	5	3	15	28	0,4
WTRP06	6	7	3	17	33	0,8
WTRP07	7	8	3,5	18	37	1,1
WTRP08	8	9	4	18	37	1,3
WTRP10	10	11	5	20,5	42	2,2
WTRP12	12	13	6	23	44	3,1
WTRP14	14	15	7	24	45	5
WTRP16	16	15	8	24,5	46	7

**WTRUC-PRD**

Union connector for DIN profile

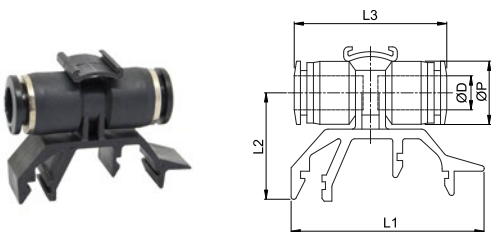

CODE	ØD	ØP	L1	L2	L3	g
WTRUC-PRD04	4	11,1	45	22	34,6	8
WTRUC-PRD06	6	13	45	22	35,2	8
WTRUC-PRD08	8	15,1	45	22,7	39,1	10
WTRUC-PRD10	10	18,8	45	24,7	45,2	17
WTRUC-PRD12	12	21,5	45	26	49,2	20

**WTRCV**

Applicable sleeve

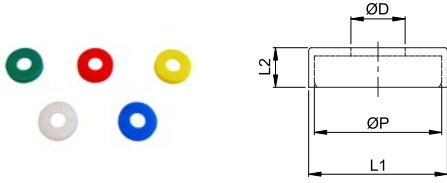

CODE	ØD	ØP	L1	L2	g
WTRCV04	4,3	10,1	11	2,4	0,1
WTRCV06	6,3	12,1	13	2,6	0,14
WTRCV08	8,3	14,1	15	2,8	0,18

ØD	BLUE	RED	WHITE	YELLOW	GREEN
4	WTRCV04BL	WTRCV04RO	WTRCV04BO	WTRCV04GL	WTRCV04VD
6	WTRCV06BL	WTRCV06RO	WTRCV06BO	WTRCV06GL	WTRCV06VD
8	WTRCV08BL	WTRCV08RO	WTRCV08BO	WTRCV08GL	WTRCV08VD



# WTR SERIES FLOW REGULATORS

PLUS

**EASY REGULATION THANKS TO THE  
HANDLE**

---

**AVAILABLE IN TWO VERSIONS, FOR  
EXHAUST (BLACK COLLET) AND FOR  
SUPPLY (RED COLLET)**

---

**WIDE RANGE FROM Ø4 TO Ø12  
WITH TEFLON TAPER GAS AND  
PARALLEL GAS THREADS**

---

**PRECISE REGULATION THAT ALLOWS  
AN ACCURATE FLOW DOSAGE WITH  
LIMITED PRESSURE LOSS**



WTR SERIES / BANJO FLOW REGULATORS



p. 37 / **WTRFR-R**



p. 37 / **WTRFR-R-IN**



p. 38 / **WTRFR-G**



p. 38 / **WTRFR-G-IN**

WTR SERIES / FLAT FLOW REGULATORS



p. 41 / **WTRNSF**

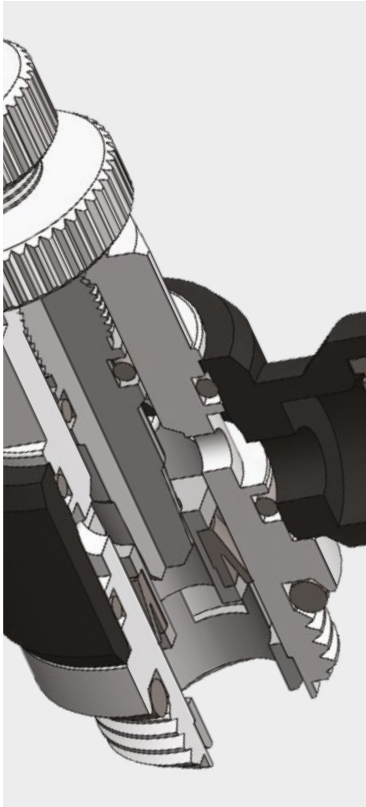

0°C ÷ 60°C

**Working pressure:**

10 Bar

**Negative pressure:**

- 0,95 Bar (- 95 Kpa)



Compressed air &amp; Vacuum

- Taper gas BSPT ISO 7  
from R1/8" to R1/2" with teflon- Parallel gas BSPP ISO 228  
from G1/8" to G1/2"- Metric ISO 262  
M5Polyamide PA,  
Polyurethane PU,  
Polyethylene PE

Manual flow regulation

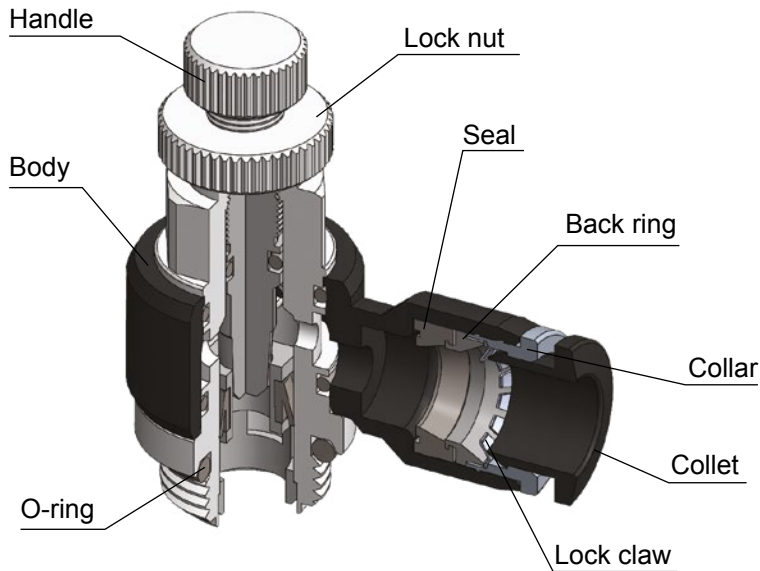
**Body:** Nickel-plated brass and PBT**Collet:** POM**Collar:** Zinc**Lock claw:** Stainless steel AISI 301**Back ring:** POM**Seal:** NBR silicone free**O-ring:** NBR silicone free**Handle:** Nickel-plated brass**Lock nut:** Nickel-plated brass**SILICONE FREE**Products in compliance with  
EC Regulation 1907/2006**RoHS3**Products in compliance with  
the directive EU 2015/863**CONSTRUCTION DETAILS****EXHAUST (FOR CYLINDERS)**

black collet

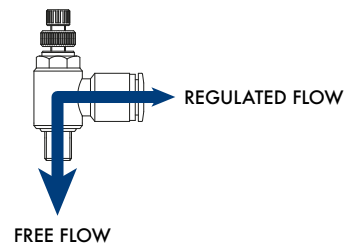
**SUPPLY (FOR VALVES)**

red collet

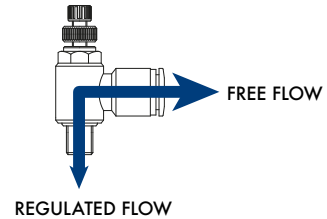
**TIGHTENING TORQUE**

TAPER GAS BSPT ISO 7

THREAD	1/8"	1/4"	3/8"	1/2"
Nm	7	12	22	28

**TIGHTENING TORQUE**

PARALLEL GAS BSPP ISO 228 &amp; METRIC ISO 262

THREAD	M5x0,8	1/8"	1/4"	3/8"	1/2"
Nm	1,5	10	15	25	40

**WTRFR-R**

Banjo male elbow flow regulator unidirectional, for cylinders, BSPT thread with handle regulation

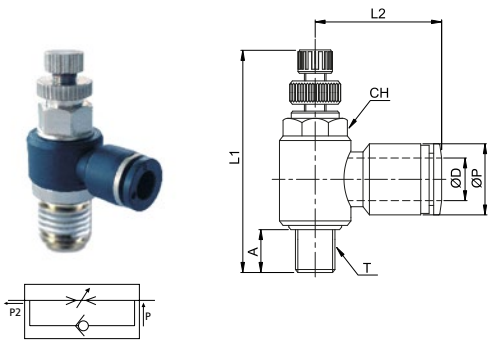

CODE	ØD	T	ØP	L1	L2	A	CH	g
WTRFR04R01	4	R 1/8"	11,1	39,7	22,3	7	10	18
WTRFR04R02		R 1/4"	11,1	45,5	24,1	9,5	14	35,9
WTRFR06R01	6	R 1/8"	13	39,7	23,1	7	10	18,5
WTRFR06R02		R 1/4"	13	45,5	25,1	9,5	14	36,5
WTRFR06R03		R 3/8"	13	52	26,8	10,5	19	60,5
WTRFR06R04	6	R 1/2"	13	58	29,8	13,5	24	92,7
WTRFR08R01	8	R 1/8"	15,1	39,7	25,6	7	10	19,3
WTRFR08R02		R 1/4"	15,1	45,5	28,6	9,5	14	37,3
WTRFR08R03		R 3/8"	15,1	52	29,6	10,5	19	61,1
WTRFR08R04		R 1/2"	15,1	58	32,6	13,5	24	93,4
WTRFR10R01	10	R 1/8"	18,8	39,7	28,8	7	10	22,7
WTRFR10R02		R 1/4"	18,8	45,5	31	9,5	14	40,7
WTRFR10R03		R 3/8"	18,8	52	31,6	10,5	19	64,5
WTRFR10R04		R 1/2"	18,8	58	34,6	13,5	24	96,8
WTRFR12R02	12	R 1/4"	21,5	45,5	33,5	9,5	14	42,2
WTRFR12R03		R 3/8"	21,5	52	35,6	10,5	19	66,1
WTRFR12R04		R 1/2"	21,5	58	36,6	13,5	24	98,3

**WTRFR-R-IN**

Banjo male elbow flow regulator unidirectional, for valves, BSPT thread with handle regulation

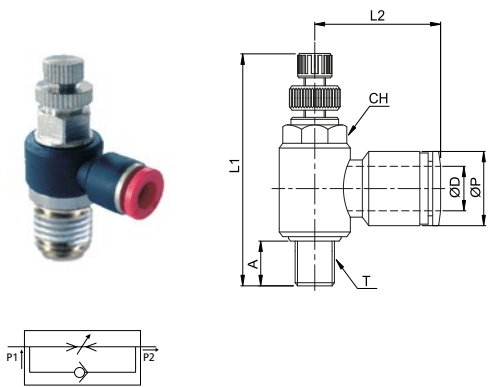

CODE	ØD	T	ØP	L1	L2	B	H	g
WTRFR04R01-IN	4	R 1/8"	11,1	39,7	22,3	7	10	18
WTRFR04R02-IN		R 1/4"	11,1	45,5	24,1	9,5	14	35,9
WTRFR06R01-IN	6	R 1/8"	13	39,7	23,1	7	10	18,5
WTRFR06R02-IN		R 1/4"	13	45,5	25,1	9,5	14	36,5
WTRFR06R03-IN		R 3/8"	13	52	26,8	10,5	19	60,5
WTRFR06R04-IN	6	R 1/2"	13	58	29,8	13,5	24	92,7
WTRFR08R01-IN	8	R 1/8"	15,1	39,7	25,6	7	10	19,3
WTRFR08R02-IN		R 1/4"	15,1	45,5	28,6	9,5	14	37,3
WTRFR08R03-IN		R 3/8"	15,1	52	29,6	10,5	19	61,1
WTRFR08R04-IN		R 1/2"	15,1	58	32,6	13,5	24	93,4
WTRFR10R01-IN	10	R 1/8"	18,8	39,7	28,8	7	10	22,7
WTRFR10R02-IN		R 1/4"	18,8	45,5	31	9,5	14	40,7
WTRFR10R03-IN		R 3/8"	18,8	52	31,6	10,5	19	64,5
WTRFR10R04-IN		R 1/2"	18,8	58	34,6	13,5	24	96,8
WTRFR12R02-IN	12	R 1/4"	21,5	45,5	33,5	9,5	14	42,2
WTRFR12R03-IN		R 3/8"	21,5	52	35,6	10,5	19	66,1
WTRFR12R04-IN		R 1/2"	21,5	58	36,6	13,5	24	98,3

**WTRFR-G**

Banjo male elbow flow regulator unidirectional, for cylinders, BSPP &amp; metric thread with handle regulation

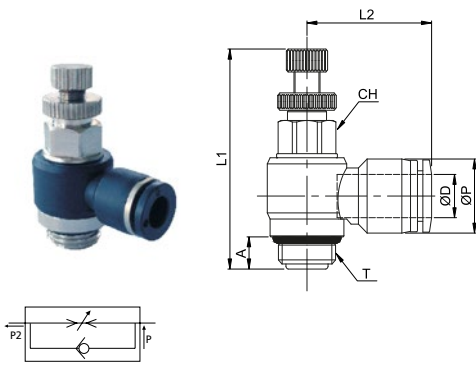

CODE	ØD	T	ØP	A	L1	L2	CH	g
WTRFR04M5	4	M5x0,8	11,1	4	29,3	20	8	15
WTRFR04G01		G 1/8"	11,1	5	39,7	22,3	8	18
WTRFR04G02		G 1/4"	11,1	6	45,5	24,1	12	36
WTRFR06M5	6	M5x0,8	13	4	29,3	21,9	8	17
WTRFR06G01		G 1/8"	13	5	39,7	23,1	8	18,5
WTRFR06G02		G 1/4"	13	6	45,5	25,1	12	36,5
WTRFR06G03		G 3/8"	13	7,2	52	26,8	14	60,5
WTRFR06G04		G 1/2"	13	8,2	58	29,8	17	92,7
WTRFR08G01	8	G 1/8"	15,1	5	39,7	25,6	8	19,3
WTRFR08G02		G 1/4"	15,1	6	45,5	8,6	12	37,3
WTRFR08G03		G 3/8"	15,1	7,2	52	29,6	14	61,1
WTRFR08G04		G 1/2"	15,1	8,2	58	32,6	17	93,4
WTRFR10G01	10	G 1/8"	18,8	5	39,7	28,8	8	22,7
WTRFR10G02		G 1/4"	18,8	6	45,5	31,1	12	40,7
WTRFR10G03		G 3/8"	18,8	7,2	52	31,6	14	64,5
WTRFR10G04		G 1/2"	18,8	8,2	58	34,6	17	96,8
WTRFR12G02	12	G 1/4"	21,5	6	45,5	33,5	12	42,2
WTRFR12G03		G 3/8"	21,5	7,2	52	35,6	14	66,1
WTRFR12G04		G 1/2"	21,5	8,2	58	36,6	17	98,3

**WTRFR-G-IN**

Banjo male elbow flow regulator unidirectional, for valves, BSPP &amp; metric thread with handle regulation

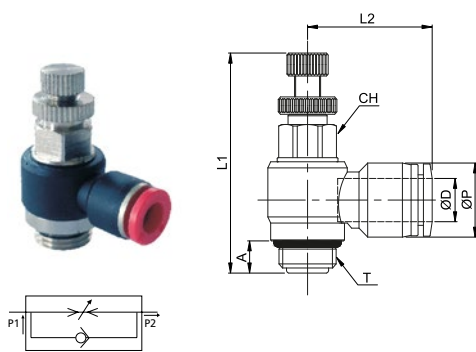

CODE	ØD	T	ØP	A	L1	L2	CH	g
WTRFR04M5-IN	4	M5x0,8	11,1	4	29,3	20	8	15
WTRFR04G01-IN		G 1/8"	11,1	5	39,7	22,3	8	18
WTRFR04G02-IN		G 1/4"	11,1	6	45,5	24,1	12	36
WTRFR06M5-IN	6	M5x0,8	13	4	29,3	21,9	8	17
WTRFR06G01-IN		G 1/8"	13	5	39,7	23,1	8	18,5
WTRFR06G02-IN		G 1/4"	13	6	45,5	25,1	12	36,5
WTRFR06G03-IN		G 3/8"	13	7,2	52	26,8	14	60,5
WTRFR06G04-IN		G 1/2"	13	8,2	58	29,8	17	92,7
WTRFR08G01-IN	8	G 1/8"	15,1	5	39,7	25,6	8	19,3
WTRFR08G02-IN		G 1/4"	15,1	6	45,5	8,6	12	37,3
WTRFR08G03-IN		G 3/8"	15,1	7,2	52	29,6	14	61,1
WTRFR08G04-IN		G 1/2"	15,1	8,2	58	32,6	17	93,4
WTRFR10G01-IN	10	G 1/8"	18,8	5	39,7	28,8	8	22,7
WTRFR10G02-IN		G 1/4"	18,8	6	45,5	31,1	12	40,7
WTRFR10G03-IN		G 3/8"	18,8	7,2	52	31,6	14	64,5
WTRFR10G04-IN		G 1/2"	18,8	8,2	58	34,6	17	96,8
WTRFR12G02-IN	12	G 1/4"	21,5	6	45,5	33,5	12	42,2
WTRFR12G03-IN		G 3/8"	21,5	7,2	52	35,6	14	66,1
WTRFR12G04-IN		G 1/2"	21,5	8,2	58	36,6	17	98,3

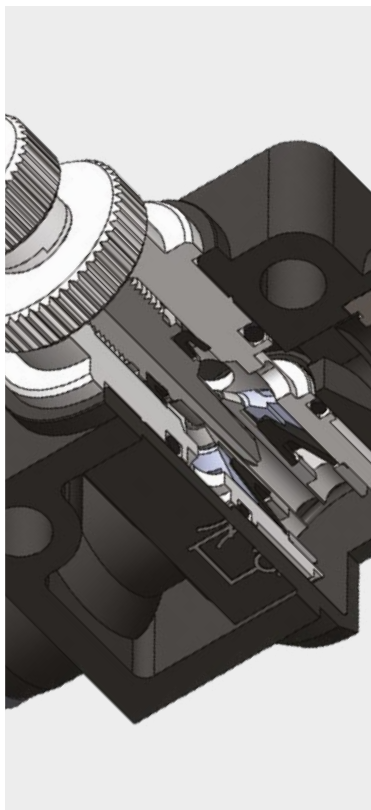

0°C ÷ 60°C



Working pressure:

10 Bar

Negative pressure:

- 0,95 Bar ( - 95 Kpa)



Compressed air & Vacuum



Polyamide PA,  
Polyurethane PU,  
Polyethylene PE



Manual flow regulation

Body: PBT

Collet: POM

Collar: Zinc

Lock claw: Stainless steel AISI 301



Back ring: POM

Seal: NBR

O-ring: NBR

Handle: Nickel-plated brass

Lock nut: Nickel-plated brass

**SILICONE FREE**



Products in compliance with  
EC Regulation 1907/2006

**RoHS3**

Products in compliance with  
the directive EU 2015/863

## CONSTRUCTION DETAILS

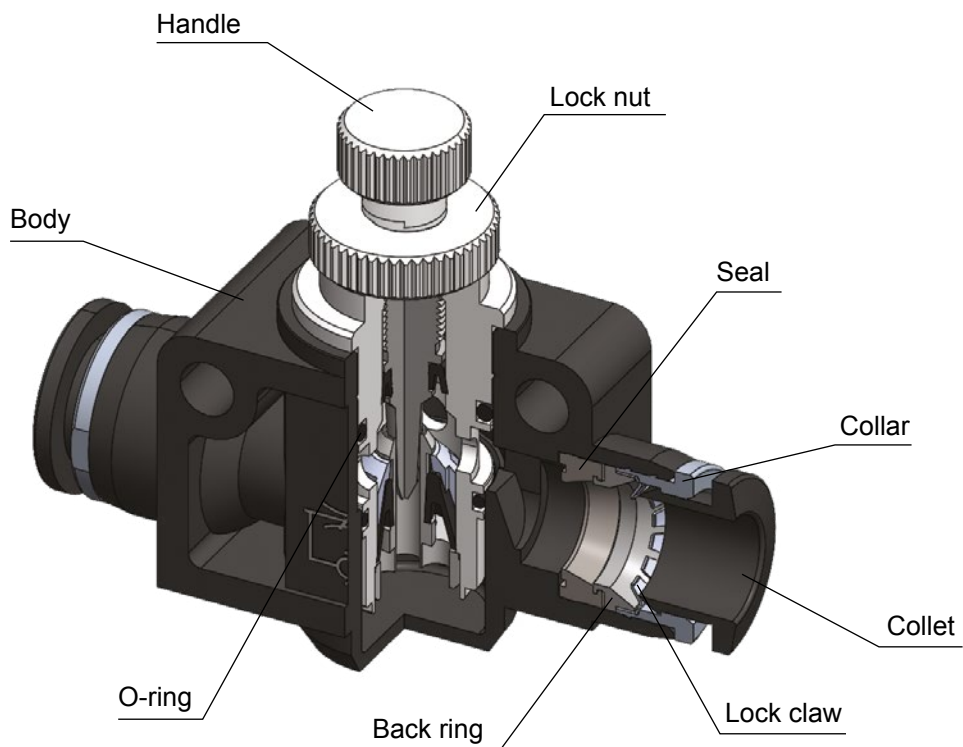

**WTRNSF**

Unidirectional flat flow regulator with handle regulation

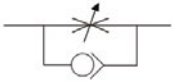
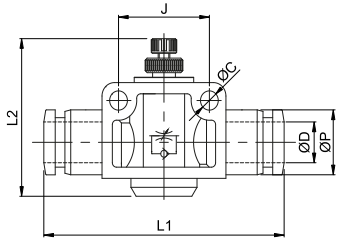

CODE	ØD	ØP	ØC	J	L1	L2	g
WTRNSF04	4	11,1	3,2	14	39,5	28,8	11,7
WTRNSF06	6	13	4,3	20	47,6	42,6	27
WTRNSF08	8	15,1	4,3	22	52,6	44,3	39,5
WTRNSF10	10	18,8	4,3	26	60,5	53,4	69
WTRNSF12	12	21,5	4,3	32	74,2	55,6	113,2

# WTR SERIES HAND VALVES

PLUS

**COMPACT AND EXTREMELY LIGHT**

---

**GREAT VACUUM RESISTANCE**

---

**AVAILABLE IN VARIOUS  
CONFIGURATIONS**

---

**2-WAY VERSION AVAILABLE ON  
DEMAND**

---

**ALLOWS TO CLOSE AND DISCHARGE  
THE PRESSURE DOWNSTREAM**



p. 45 / **WTRFS-R**



p. 45 / **WTRFS-G**



p. 46 / **WTRSF-R**



p. 46 / **WTRSF-G**



p. 47 / **WTRSS-R**



p. 47 / **WTRSS-G**



p. 48 / **WTRFF**



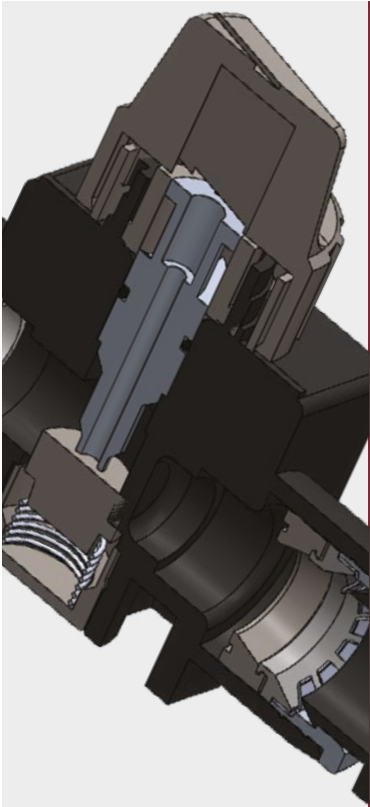

0°C ÷ 60°C



**Working pressure:**  
from 0 to 10 Bar  
**Negative pressure:**  
- 0,95 Bar ( - 95 Kpa)



Compressed air & vacuum  
(do not use with water)



- Taper gas BSPT ISO 7  
from R1/8" to R1/2" with teflon  
- Parallel gas BSPP ISO 228  
from G1/8" to G1/2" with o-ring



Polyamide PA, Polyurethane PU

## AVAILABILITY

Available in 2-way version (with blue handle)

Body: Nickel-plated brass and PBT

Lock claw: Stainless steel AISI 301

Seal: NBR silicone free



Collet: POM

Valve: POM

Handle: POM (Black)

Back ring: POM

Collar: Nickel-plated zinc



Products in compliance with  
EC Regulation 1907/2006



Products in compliance with  
the directive EU 2015/863

## CONSTRUCTION DETAILS

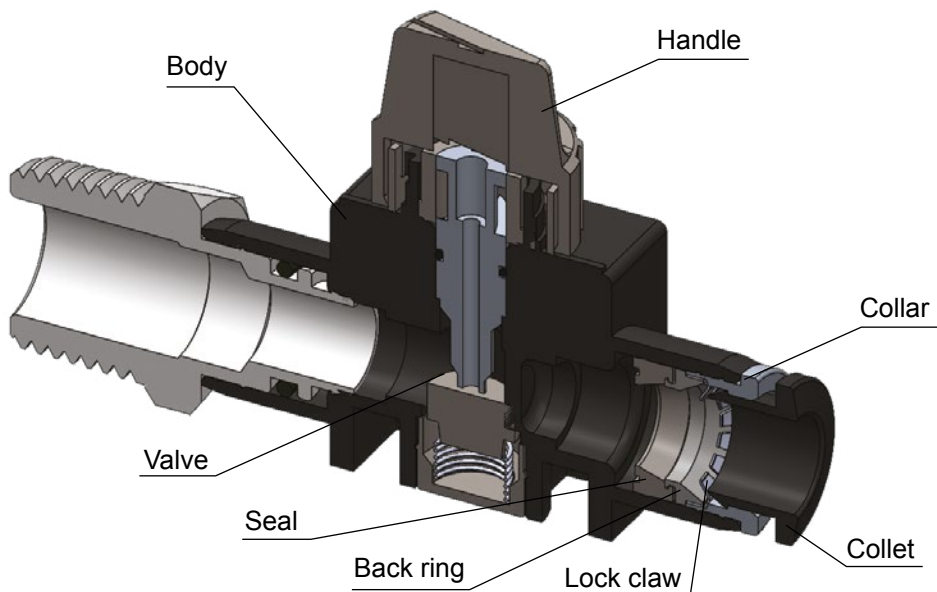

**WTRFS-R**

Male hand valve BSPT thread, flow tube-thread

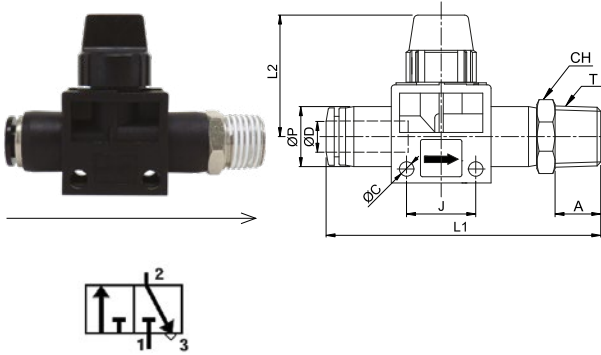

CODE	ØD	T	ØP	ØC	A	L1	L2	J	CH
WTRFS06R01	6	R 1/8"	14,5	4,2	7	58,3	29,5	16,5	14
WTRFS06R02		R 1/4"	14,5	4,2	9,5	60,8	29,5	16,5	14
WTRFS06R03		R 3/8"	14,5	4,2	10,5	62,3	29,5	16,5	17
WTRFS08R01	8	R 1/8"	14,5	4,2	7	59,4	29,5	16,5	17
WTRFS08R02		R 1/4"	14,5	4,2	9,5	61,9	29,5	16,5	17
WTRFS08R03		R 3/8"	14,5	4,2	10,5	62,9	29,5	16,5	17
WTRFS10R02	10	R 1/4"	20,9	4,2	9,5	73,8	31	21,5	20
WTRFS10R03		R 3/8"	20,9	4,2	10,5	74,8	31	21,5	20
WTRFS10R04		R 1/2"	20,9	4,2	13,5	77,8	31	21,5	21
WTRFS12R02	12	R 1/4"	20,9	4,2	9,5	73,4	31	21,5	21
WTRFS12R03		R 3/8"	20,9	4,2	10,5	74,4	31	21,5	21
WTRFS12R04		R 1/2"	20,9	4,2	13,5	77,4	31	21,5	21

**WTRFS-G**

Male hand valve BSPP thread, flow tube-thread

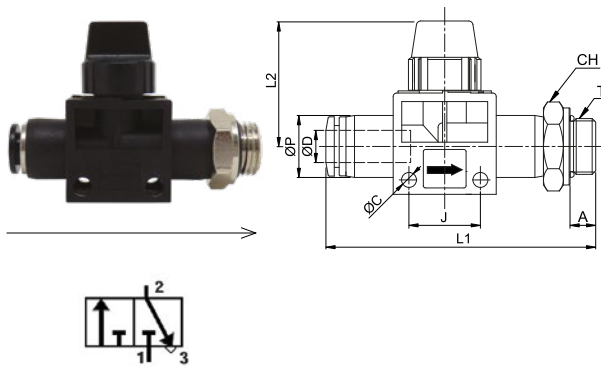

CODE	ØD	T	ØP	ØC	A	L1	L2	J	CH
WTRFS06G01	6	G 1/8"	14,5	4,2	5	57,8	29,5	16,5	14
WTRFS06G02		G 1/4"	14,5	4,2	5,8	59,1	29,5	16,5	14
WTRFS06G03		G 3/8"	14,5	4,2	6,8	60,6	29,5	16,5	17
WTRFS08G01	8	G 1/8"	14,5	4,2	5	58,9	29,5	16,5	17
WTRFS08G02		G 1/4"	14,5	4,2	5,8	59,7	29,5	16,5	17
WTRFS08G03		G 3/8"	14,5	4,2	6,8	61,2	29,5	16,5	20
WTRFS10G02	10	G 1/4"	20,9	4,2	5,8	72,1	31	21,5	20
WTRFS10G03		G 3/8"	20,9	4,2	6,8	73,1	31	21,5	20
WTRFS10G04		G 1/2"	20,9	4,2	8	74,8	31	21,5	24
WTRFS12G02	12	G 1/4"	20,9	4,2	5,8	71,7	31	21,5	21
WTRFS12G03		G 3/8"	20,9	4,2	6,8	72,7	31	21,5	21
WTRFS12G04		G 1/2"	20,9	4,2	8	74,4	31	21,5	24

**WTRSF-R**

Male hand valve BSPT thread, flow thread-tube

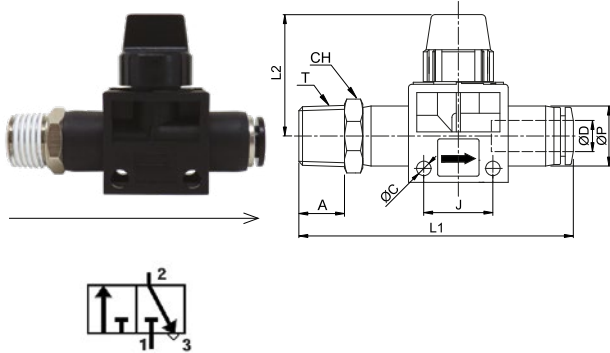

CODE	ØD	T	ØP	ØC	A	L1	L2	J	CH
WTRSF06R01	6	R 1/8"	14,5	4,2	7	58,3	29,5	16,5	14
WTRSF06R02		R 1/4"	14,5	4,2	9,5	60,8	29,5	16,5	14
WTRSF06R03		R 3/8"	14,5	4,2	10,5	62,3	29,5	16,5	17
WTRSF08R01	8	R 1/8"	14,5	4,2	7	59,4	29,5	16,5	17
WTRSF08R02		R 1/4"	14,5	4,2	9,5	61,9	29,5	16,5	17
WTRSF08R03		R 3/8"	14,5	4,2	10,5	62,9	29,5	16,5	17
WTRSF10R02	10	R 1/4"	20,9	4,2	9,5	73,8	31	21,5	20
WTRSF10R03		R 3/8"	20,9	4,2	10,5	74,8	31	21,5	20
WTRSF10R04		R 1/2"	20,9	4,2	13,5	77,8	31	21,5	21
WTRSF12R02	12	R 1/4"	20,9	4,2	9,5	73,4	31	21,5	21
WTRSF12R03		R 3/8"	20,9	4,2	10,5	74,4	31	21,5	21
WTRSF12R04		R 1/2"	20,9	4,2	13,5	77,4	31	21,5	21

**WTRSF-G**

Male hand valve BSPP thread, flow thread-tube

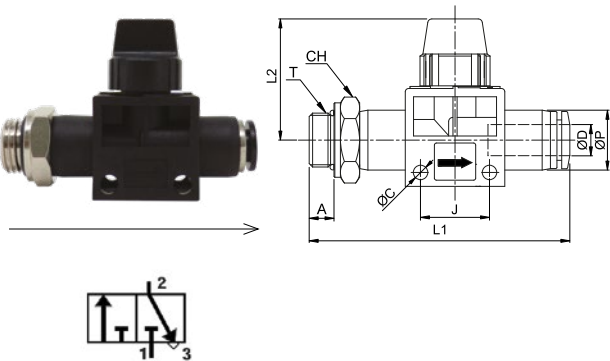

CODE	ØD	T	ØP	ØC	A	L1	L2	J	CH
WTRSF06G01	6	G 1/8"	14,5	4,2	5	57,8	29,5	16,5	14
WTRSF06G02		G 1/4"	14,5	4,2	5,8	59,1	29,5	16,5	14
WTRSF06G03		G 3/8"	14,5	4,2	6,8	60,6	29,5	16,5	17
WTRSF08G01	8	G 1/8"	14,5	4,2	5	58,9	29,5	16,5	17
WTRSF08G02		G 1/4"	14,5	4,2	5,8	59,7	29,5	16,5	17
WTRSF08G03		G 3/8"	14,5	4,2	6,8	61,2	29,5	16,5	20
WTRSF10G02	10	G 1/4"	20,9	4,2	5,8	72,1	31	21,5	20
WTRSF10G03		G 3/8"	20,9	4,2	6,8	73,1	31	21,5	20
WTRSF10G04		G 1/2"	20,9	4,2	8	74,8	31	21,5	24
WTRSF12G02	12	G 1/4"	20,9	4,2	5,8	71,7	31	21,5	21
WTRSF12G03		G 3/8"	20,9	4,2	6,8	72,7	31	21,5	21
WTRSF12G04		G 1/2"	20,9	4,2	8	74,4	31	21,5	24

### WTRSS-R

Male hand valve BSPT thread, flow thread-thread

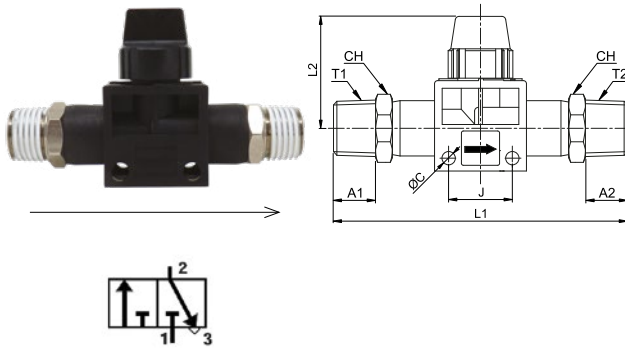

CODE	T1	T2	ØC	A1	A2	L1	L2	J	CH1	CH2
WTRSS01R01	R 1/8"	R 1/8"	4,2	7	7	65	29,5	16,5	14	14
WTRSS02R02	R 1/4"	R 1/4"	4,2	9,5	9,5	70	29,5	16,5	14	14
WTRSS03R03	R 3/8"	R 3/8"	4,2	10,5	10,5	74	29,5	16,5	17	17
WTRSS04R04	R 1/2"	R 1/2"	4,2	13,5	13,5	90,5	31	21,5	21	21
REDUCED MALE HAND VALVE BSPT THREAD, FLOW THREAD-THREAD										
WTRSS02R01	R 1/4"	R 1/8"	4,2	9,5	7	67,5	29,5	16,5	14	14
WTRSS03R02	R 3/8"	R 1/4"	4,2	10,5	9,5	73	29,5	16,5	17	17
WTRSS04R03	R 1/2"	R 3/8"	4,2	13,5	10,5	87,5	31	21,5	21	21

### WTRSS-G

Male hand valve BSPP thread, flow thread-thread

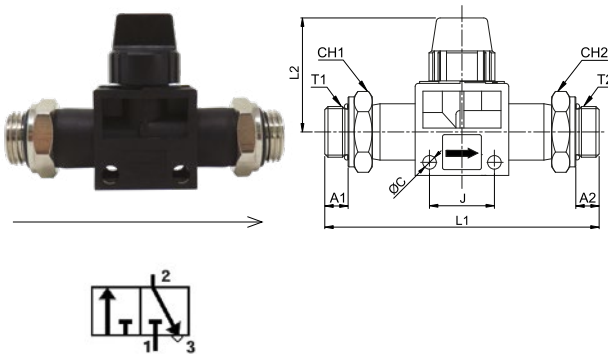

CODE	T1	T2	ØC	A1	A2	L1	L2	J	CH1	CH2
WTRSS01G01	G 1/8"	G 1/8"	4,2	5	5	64	29,5	16,5	14	14
WTRSS02G02	G 1/4"	G 1/4"	4,2	5,8	5,8	66,6	29,5	16,5	17	17
WTRSS03G03	G 3/8"	G 3/8"	4,2	6,8	6,8	70,6	29,5	16,5	20	20
WTRSS04G04	G 1/2"	G 1/2"	4,2	8	8	84,5	31	16,5	24	24
REDUCED HAND VALVE BSPP THREAD, FLOW THREAD-THREAD										
WTRSS02G01	G 1/4"	G 1/8"	4,2	5,8	5	65,3	29,5	16,5	17	14
WTRSS03G02	G 3/8"	G 1/4"	4,2	6,8	5,8	69,6	29,5	16,5	20	17
WTRSS04G03	G 1/2"	G 3/8"	4,2	8	6,8	82,8	31	21,5	24	20

**WTRFF**

Union hand valve, flow tube-tube

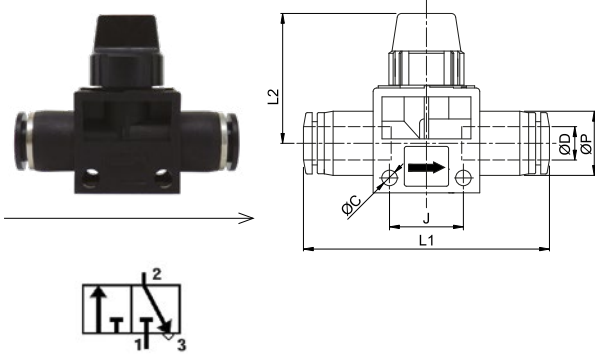

CODE	ØD	ØP	ØC	L1	L2	J
WTRFF0606	6	14,5	4,2	51,6	29,5	16,5
WTRFF0808	8	14,5	4,2	52,8	29,5	16,5
WTRFF1010	10	20,9	4,2	65,1	31	21,5
WTRFF1212	12	20,9	4,2	64,3	31	21,5